

 OXFORD



2022/23

MOTORCYCLE ACCESSORIES

MAKING LIFE ON BIKES BETTER SINCE 1973



A GLOBAL LEADER

A GLOBAL LEADER IN MOTORCYCLE AFTERMARKET PRODUCTS

Established in 1973, OXFORD is now one of the world's leading suppliers of products to the two-wheeled industry. From its base in Oxfordshire, the company distributes to around 100 partners worldwide and around two thousand domestically.

Its huge range of products encompasses everything which makes life on bikes better: from clothing and helmets to accessories, hard parts, locks and luggage and more! Following unprecedented investment in staff, product development and infrastructure, the company now employs around 170 people.

Having established an impressive growth curve, which has seen turnover doubling every 5 years, the company has further ambitious expansion plans both at home and abroad.

COMMITTED TO DEVELOPMENT

OXFORD products are designed in-house by a combined team of active enthusiasts and skilled technicians. They use the latest CAD technology and 3D printing techniques to innovate, analyse, test and develop the range in pursuit of the best product experience for their customers.

In addition to OXFORD branded products, the company uses its expertise to design and produce for many other labels around the world. Like many of its products, which have wider appeal in other leisure and outdoor-based markets, this activity is not restricted to the two-wheeled industry.

Making life on bikes better since 1973



OXFORD HQ

A bespoke 100,000 SQ FT facility opened by Prime Minister David Cameron in 2014 has recently been expanded with additional warehousing, a video & photography suite and a new Design, Research & Development Centre

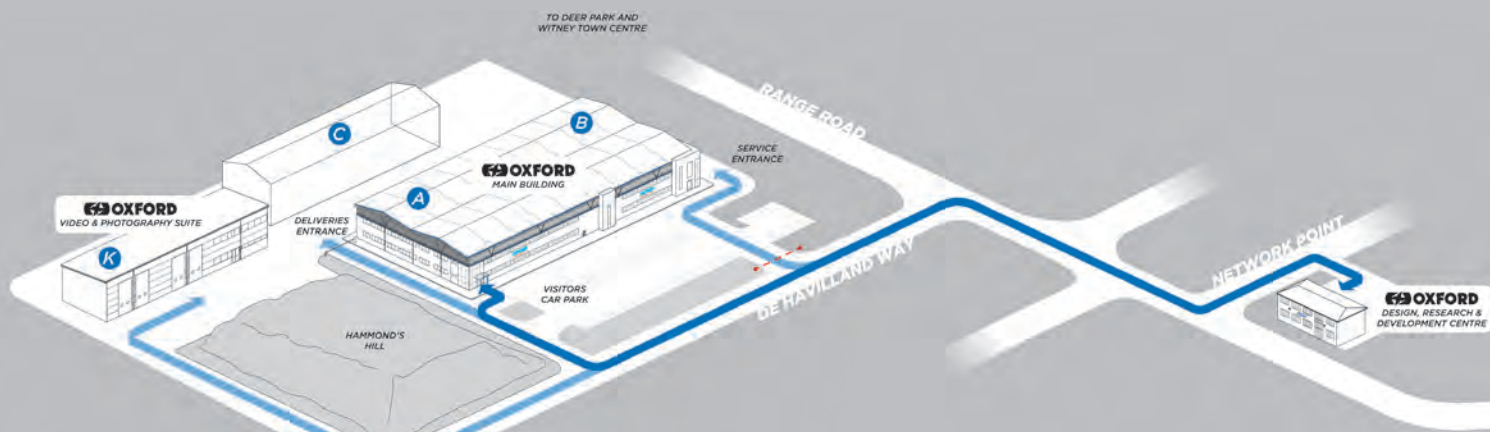

- A** WAREHOUSE
- B** WAREHOUSE
- C** WAREHOUSE
- K** WAREHOUSE
- L** WAREHOUSE

--- SPECIAL ACCESS ONLY



IN HOUSE PRODUCT DEVELOPMENT

3D Printing allows rapid CAD design and prototyping to enhance product development



IN HOUSE STATE-OF-THE-ART TESTING FACILITIES

Oxford is able to test all products in house with a state-of-the-art laboratory

OXFORD UK

Oxford Essential Rider Equipment is distributed in the UK by a network of retail partners.

☎ Telephone: 01993 862 300

✉ Email: info@oxprod.com

🌐 Web: www.oxfordproducts.com

Online store (trade-only): Retail partners can view stock availability, prices and place orders online via a secure log-in. Please contact trade@oxprod.com for more information.

AROUND THE WORLD

OXFORD is a remarkable British success story!

For nearly five decades the company has waved the flag for British ingenuity and innovation and is proud to have distribution partners in all corners of the globe.

In return, foreign markets have provided many fresh ideas to OXFORD's product range; the challenges of widely varying climates, customs and terrain have only served to enrich the company's offering.

You will find a full distributor list at www.oxfordproducts.com. Please contact us for further information:

Tel: (+44) 1993 862 300

Fax: (+44) 1993 862 320

For export trade enquiries email us at export@oxprod.com

CONTENTS

SECURITY	8
Chain Locks	10
Accessories	16
U-Locks	18
Anchors	20
Disc Locks	26
Chains	32
COVERS	34
BATTERY CARE	44
WORKSHOP	51
Zero-G	51
Paddock Stands	68
Bike Care	73
Cleaning	86
MINT	93
Cleaning	95
Lubes	97
Detailing	98
Kit Care	99
TYRE CARE	101
Tyre Warmers	102
Pumps & Gauges	102
Valve Accessories	104
Puncture Repair	105
PAINT PROTECTION	106
LIGHTING	111
Dynamic Indicators	112
Indicators	116
Accessories	120
HANDLEBAR ACCESSORIES	122
Hotgrips™	122
Grips	129
Barends	132
Lever Guards	134
Mirrors	136
Muffs	140
Phone Accessories	144
HELMET ACCESSORIES	154
TRAVEL & TRANSPORT	158
LUGGAGE	164
Aqua	166
S-Series	174
R-Series	176
Heritage	182
F-1	184
MERCHANDISING	192
INDEX	195

KEEP UP TO DATE



FACEBOOK
[@OxfordProducts](https://www.facebook.com/OxfordProducts)



YOUTUBE
[/OxfordProductsLtd](https://www.youtube.com/OxfordProductsLtd)



TWITTER
[/oxfordproducts.com](https://twitter.com/oxfordproducts.com)



LINKEDIN
[/oxford-products.ltd](https://www.linkedin.com/company/oxford-products.ltd)



INSTAGRAM
[@OxfordProducts](https://www.instagram.com/OxfordProducts)

DESIGN DEVELOPMENT PROCESS

At its heart, Oxford is a products company – Oxford Products! The team develops its products in-house, increasingly through the use of Computer Aided Design. In order to maximise the benefits of CAD, the company has invested in the latest 3D print technology.

This means that a product or component designed today can be printed off overnight and tested tomorrow. The day after, our factory can be making the moulds and production can begin shortly after. In this way, product development time is dramatically reduced and the end result far more relevant and ambitious. Here is a typical design cycle for an Oxford product...

INITIAL CONCEPT SKETCHING



SCHEMATIC LAYOUT

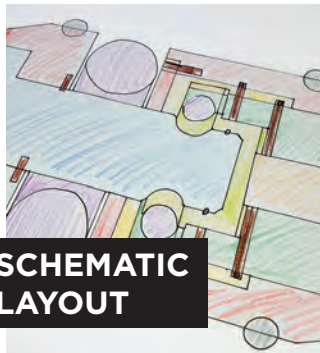

3D MODELING

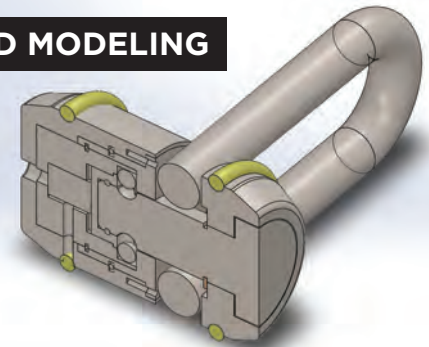

SKETCH RENDER

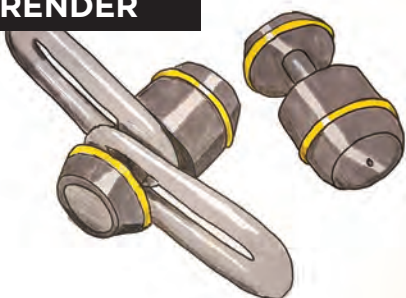

MECHANICAL DESIGN

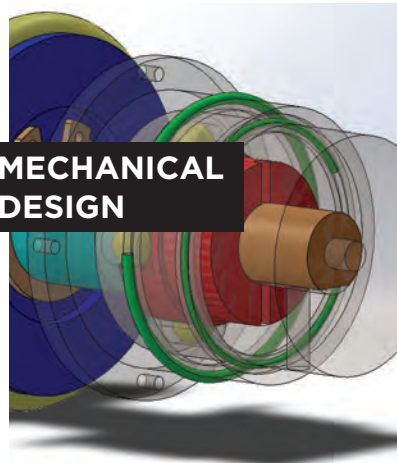

DESIGN ANALYSIS

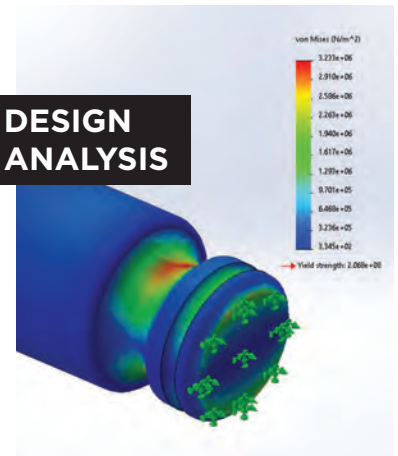

NETWORK POINT



OXFORD
DESIGN, RESEARCH &
DEVELOPMENT CENTRE

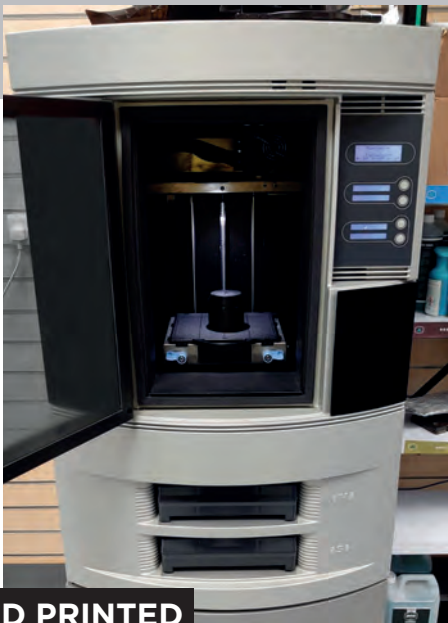

3D PRINTED PARTS



PRODUCT TESTING



FINISHED PRODUCT

TECHNICAL DRAWINGS

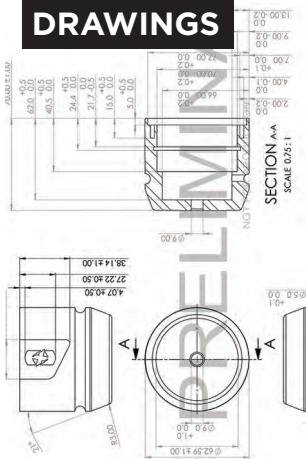

VISUALISATION





PRODUCT TESTING

Our products are rigorously tested for both real-world usability, and relevant product standards. Having this facility in-house enables us to develop products which are measurably better, faster.

ACCELERATED WEATHER TESTER





5000KG TENSILE TESTING SYSTEM

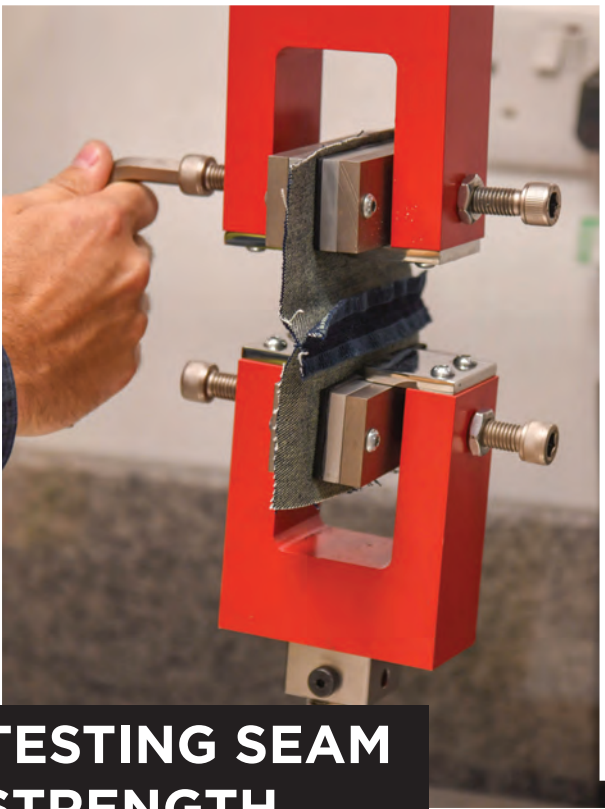

TESTING SEAM STRENGTH



WATERPROOF & BREATHABILITY TEST DEVICE



SECURITY

Motorcycles are fundamentally more vulnerable to theft than most other forms of transport, but they need not be. The use of a good lock will protect a motorcycle against most forms of attack and reduce the theft rate dramatically. Incredibly, motorcycle security experts still believe that well over half of all motorcyclists use no form of physical security other than the steering lock, which itself offers very little resistance to a determined attack.

Furthermore, just like an alarm or an immobiliser, the steering lock does not prevent thieves from simply lifting the motorcycle into the back of a van and transporting it to a garage where they can re-mobilise the bike at their leisure.

These figures are supported by recent research carried out by Oxford Products Ltd in the UK's capital London, the UK's worst theft hotspot. A survey of 736 bikes revealed just 287 using locks, meaning that 61% of bikes were unsecured! If you want to keep your bike, the best advice is simple: Lock it up!

THE FACTS ABOUT THEFT

Motorcycle theft remains a huge problem, both in the UK and abroad. Every year thousands of motorcycles are stolen and motorcyclists are disappointed and inconvenienced as a result.

- It takes approximately 12 seconds to steal an unprotected motorcycle.
- Approximately 70 motorcycles are stolen every day in the UK and less than 14% of stolen motorcycles are recovered.
- Theft accounts for one third of insurance claims and 40% of owners who have their bike pinched give up on bikes.

UNBELIEVABLY...

- More than half of all motorcyclists neglect to use ANY form of motorcycle security!

According to police statistics, 50% of bikes are stolen by the opportunist or "Joy-rider". Incredibly, they also estimate that 60% of riders do not lock their machines. Reduce the risk of theft by following these simple steps:

- Buy the best lock you can afford and always use it.
- Alarms can be very effective but only really effective when in conjunction with a lock.
- If you have a garage, always use it and remember to lock the bike and set the alarm - otherwise cover your bike when outside.
- When parking your bike try to avoid using the same spot every day and lock your bike to a secure immovable object, such as a ground anchor.
- Never leave your lock resting on the ground and always lock it as tight to your bike as possible - this makes it much more difficult to attack.
- Remember to maintain your lock. Keep it free from dirt and oil moving parts regularly. If your lock stops working, you won't be able to use it!



INDEPENDENTLY TESTED

SOLD SECURE

Sold Secure is the premier testing and certification house for security products in the UK. It is owned by the Master Locksmiths Association, the largest and longest established trade association for the locksmithing industry. It is the mission of Sold Secure to test and provide professional and accurate advice regarding effective security products to Commercial Customers, the Insurance Industry, the Home Office, the Police and the Public.

www.soldsecure.com

SECURED BY DESIGN

The official police security initiative that works to improve security. SBD's product based accreditation scheme - the Police Preferred Specification - provides a recognised standard for all security products that can deter and reduce crime. SBD is the only way for companies to obtain police recognition for security-related products in the UK.

www.securedbydesign.com



MOTORCYCLE DIAMOND SPEC

5 minutes, much higher tool list including angle grinders, largest bolt croppers, machine-based crop test to ensure at least 7 tonnes of force is achieved, drill with HSS bits, etc.



MOTORCYCLE GOLD SPEC

Aimed at preventing more dedicated attacks; 5 minutes; higher tool list inc. TCT hacksaw, larger croppers, larger crowbars, lump hammer, etc.



MOTORSCOOTER SILVER SPEC

Aimed at preventing more determined attacks; 3 minutes; enhanced tool list including small bolt croppers, full size hacksaw (HSS), stillsons, crowbar, etc.



BICYCLE BRONZE SPEC

Aimed at preventing opportunist theft; 1 minute attack time; basic tools that can be easily concealed about the person, i.e. screwdriver, small hammer, junior hacksaw, etc.



OTHER INTERNATIONAL APPROVALS

Oxford offers a range of security products which have been tested and approved to various international security standards.



CHAIN LOCKS



BEAST

Maximum security chain lock

Some say that size doesn't matter. When it comes to locks, it matters! The Oxford BEAST is our strongest and largest ever lock, it's so big it comes with a health warning on the box: WARNING - HEAVY! The lock alone weighs 3.6KG, the chain up to 15.5KG!

PADLOCK FEATURES

- 30mm hardened locking pin
- Designed to resist angle-grinder attack
- Surface hardened throughout
- 3.6kg weight

CHAIN FEATURES

- Durable 22mmø painted links
- Designed to resist angle-grinder attack
- 12 - 15.5kg weight

CODE	DESCRIPTION
LK126	Beast Chain- 1.5m
LK127	Beast Chain- 2.0m
LK120	Beast Lock

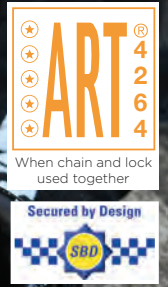
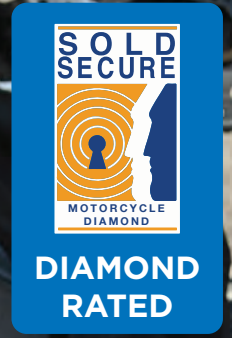

NEMESIS

16mm round link chain & 16mm shackle padlock

FEATURES

- Chain made from hardened Ni-Cro-Mo steel, reinforced with titanium alloy
- Available in 1.2m, 1.5m & 2.0m lengths
- Shock resistant padlock with rubber over-moulding
- Anti-pick and anti-drill lock cylinder



CODE	DESCRIPTION
LK472	Nemesis - 1.2m
LK473	Nemesis - 1.5m
LK474	Nemesis - 2.0m
LK470B	Nemesis - Padlock Black unpackaged



CHAIN LOCKS

BOSS ALARM

12mm square link chain
& 16mm or 14mm shackle padlock

FEATURES

- Chain made from hardened Ni-Cro-Mo steel
- Available in 1.2m, 1.5m & 2.0m lengths
- Anti-jack design padlock can withstand 4.5 tonnes of tensile load
- 6 x LR44 batteries included
- Removable, sealed unit alarm module

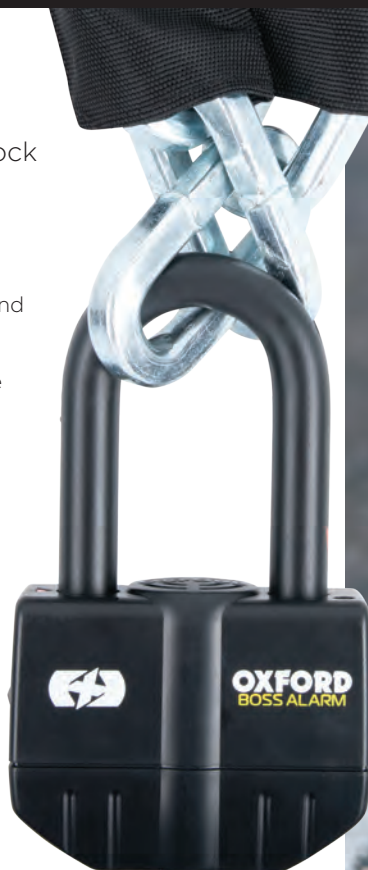

CODE	DESCRIPTION
LK480	Boss Alarm 16 Black - 1.2m
LK481	Boss Alarm 16 Black - 1.5m
LK482	Boss Alarm 16 Black - 2.0m
LK484U	Boss Alarm 16 Black - Padlock Unpackaged
LK487	Boss Alarm 14 Yellow - 1.2m
LK488	Boss Alarm 14 Yellow - 1.5m
LK489	Boss Alarm 14 Yellow - 2.0m
OF3U	Boss Alarm 14 Yellow - Padlock Unpackaged



PATRIOT

12mm square link chain
& 14mm pin padlock

FEATURES

- Chain made from hardened Ni-Cro-Mo steel
- Available in 1.2m, 1.5m & 2.0m lengths
- 14mm rotating locking pin padlock with 4 way locking system



CODE	DESCRIPTION
LK745	Patriot - 1.2m
LK746	Patriot - 1.5m
LK747	Patriot - 2.0m
LK741B	Patriot - Padlock Black Unpackaged



MONSTER

14mm hex link chain & 11mm shackle padlock

FEATURES

- Chain made from hardened Ni-Cro-Mo steel
- Available in 1.2m, 1.5m & 2.0m lengths
- Ultra-strong padlock made from hardened boron steel armour casing
- Double locking mechanism



CODE	DESCRIPTION
OF16	Monster - 1.2m
OF17	Monster - 1.5m
OF18	Monster - 2.0m
OF31	Monster - Padlock Black Unpackaged
OF19	Monster XL - 1.2m
OF20	Monster XL - 1.5m
OF21	Monster XL - 2.0m
OF22	Monster XL - Padlock Black



BOSS

12mm square link chain & 12.7mm shackle padlock

FEATURES

- Chain made from hardened Ni-Cro-Mo steel
- Available in 1.2m, 1.5m & 2.0m lengths
- Anti-pick & anti-drill lock cylinder
- Double locking mechanism

CODE	DESCRIPTION
LK382	Boss - 1.2m
LK383	Boss - 1.5m
LK384	Boss - 2.0m
LK380B	Boss - Padlock Black Unpackaged



CHAIN LOCKS

HARDCORE XC13

13mm square link chain
& 11mm shackle padlock

FEATURES

- Chain made from hardened Ni-Cro-Mo steel
- Available in 1.2m, 1.5m & 2.0m lengths
- Ultra-strong padlock made from hardened boron steel armour casing
- Shock resistant rubber over-moulding



CODE DESCRIPTION

LK170	Hardcore XC13 - 1.2m
LK171	Hardcore XC13 - 1.5m
LK172	Hardcore XC13 - 2.0m
LK169	Hardcore XC13 - Padlock Black Unpackaged



HD MAX

12mm square link chain
& 14mm shackle padlock

FEATURES

- Chain made from hardened Ni-Cro-Mo steel
- Available in 1.2m, 1.5m & 2.0m lengths
- Padlock with anti-pick & anti-drill lock cylinder
- Double locking mechanism



CODE DESCRIPTION

LK307	HD Max - 1.2m
LK308	HD Max - 1.5m
LK309	HD Max - 2.0m
LK310B	HD Max - Padlock Black Unpackaged



DISCUS CHAIN 10

9.5mm square link chain
& 10mm shackle padlock

FEATURES

- Chain made from hardened steel
- 1.5m long
- 10,000 possible combinations
- Stainless steel padlock, rust resistant body



CODE DESCRIPTION

LK101	Discus Chain 10 - 1.5m
-------	------------------------



HD CHAIN

10mm square link chain & 14mm shackle padlock

FEATURES

- Chain made from Cro-Mo steel
- Available in 1.2m, 1.5m & 2.0m
- Double locking mechanism



CODE	DESCRIPTION
OF157	HD Chain - 1.0m
OF159	HD Chain - 1.5m
OF160	HD Chain - 2.0m

GP CHAIN 10

10mm round link chain & integral lock

FEATURES

- Made from hardened steel
- Available in 1.2m, 1.5m & 2.0m
- Integral lock head
- 360° rotating lock head
- Supplied with 4 keys



CODE	DESCRIPTION
LK107	GP Chain 10 - 1.2m
LK108	GP Chain 10 - 1.5m
LK109	GP Chain 10 - 2.0m

GP CHAIN 8

8mm round link chain & integral lock

FEATURES

- Made from hardened steel
- Available in 1.2m, 1.5m & 2.0m
- Integral lock head
- 360° rotating lock head
- Supplied with 4 keys



CODE	DESCRIPTION
LK104	GP Chain 8 - 1.2m
LK105	GP Chain 8 - 1.5m
LK106	GP Chain 8 - 2.0m

OTHER LOCKS

LEVERLOCK

Brake lever & throttle lock

FEATURES

- Fits grips 28mm-38mm
- Compact, so convenient to carry on bike or in a bag
- Simple push to lock feature
- High visibility security



CODE	DESCRIPTION
------	-------------

LK300	Leverlock - Black
LK301	Leverlock - Yellow

BARRIER

Armoured cable lock

FEATURES

- 25mm x 1.4m braided steel cable
- Protected by steel rollers
- Vinyl coating to protect paintwork
- Integrated lock cylinder dust cover



CODE	DESCRIPTION
------	-------------

LK135	Barrier - Smoke
LK136	Barrier - Blue
LK137	Barrier - Red

COMBINATION PADLOCK

5-digit combination padlock

FEATURES

- Hardened steel construction
- 7mm shackle
- Weight: 178g

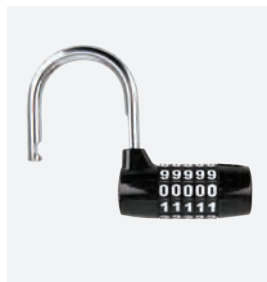

CODE	DESCRIPTION
------	-------------

LK102	5-digit combination padlock
-------	-----------------------------

RETRA CABLE

Retractable combination cable lock

Ideal lock for accessories & clothing

FEATURES

- 4-digit resettable combination
- Lightweight: 80g
- Slashproof braided steel cable
- 2.4mm x 620mm



CODE	DESCRIPTION
------	-------------

LK100	Retra Cable
-------	-------------

LOOP LOCK 15

Cable and mini shackle lock

FEATURES

- 12mm Shackle
- 15mm x 2.0m High tensile steel self-coiling cable
- Vinyl coating to protect paintwork
- Can also be used as a disc lock



CODE	DESCRIPTION
LK221	Loop Lock 15

LOOP LOCK 10

Hooped cable and padlock

FEATURES

- 7mm Shackle
- 10mm x 1.8m High tensile steel self-coiling cable
- Vinyl coating to protect paintwork
- Can also be used as a padlock

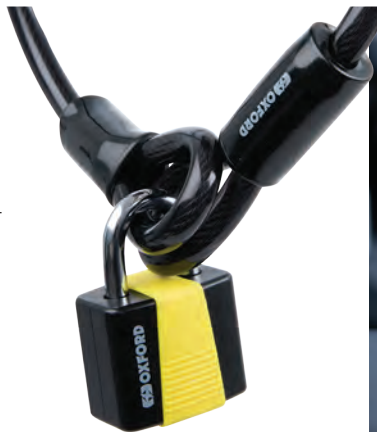

CODE	DESCRIPTION
LK222	Loop Lock 10

MINDER CABLE

Essential lock reminder cable

FEATURES

- 4mmø plastic cable
- Simple to use
- Lightweight construction
- 1.2m when stretched
- Highlights use of lock to thieves

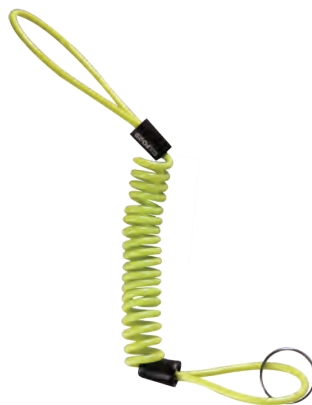

CODE	DESCRIPTION
OX795	Minder Cable (pack of 25)

MINI MINDER

Essential lock reminder cable

FEATURES

- 2.5mmø plastic cable
- Simple to use
- Lightweight construction
- 1.2m when stretched
- Highlights use of lock to thieves



CODE	DESCRIPTION
OX669	Mini Minder



U-LOCKS

MAGNUM

Ultra strong U-Lock

FEATURES

- 16mm hardened shackle
- Double locking mechanism
- 285mm & 315mm versions available
- LK225 comes with lockable cable



LK223

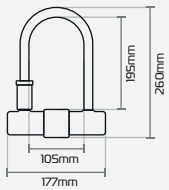

LK224 & LK225

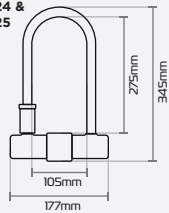

CODE DESCRIPTION

LK223	Magnum - 285mm
LK224	Magnum - 315mm
LK225	Magnum - 315mm Duo



ALARM-D

High security U-Lock with alarm

FEATURES

- 16mm hardened shackle
- Built-in 120dB alarm
- Shock-resistant rubber over-moulding
- Powered by long-life lithium CR2 battery (replaceable)

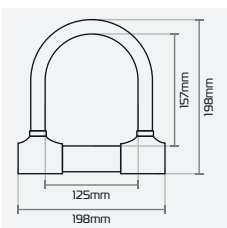

CODE DESCRIPTION

LK220	Alarm-D
-------	---------





ANCHORS

OXFORD
BEAST

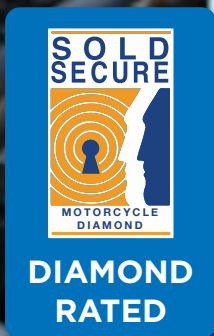

NEW BEAST FLOOR LOCK

Maximum security integrated floor lock

The Beast Floor Lock - the all-in-one security solution - is an extra strong bolt-down anchor.

The Beast has achieved a Sold Secure DIAMOND rating, ensuring it is able to withstand forceful and sustained attacks. To be awarded a DIAMOND is no small feat. The Beast has passed attack tests from a huge range of tools, commonly used by thieves including, pliers, bolt croppers, drill, and most impressively a 90 second angle grinder attack.

The Beast Floor Lock has a key replacement service. When you buy your Beast Floor Lock, simply note down the number which comes attached to the keys on a metal tag. Keep this in a safe place, then in the event that you are unfortunate enough to lose all your keys, it will be possible to get a new key made up for you.

FEATURES

- 30mm hardened locking pin
- Designed to resist angle grinder, pliers, bolt croppers attack
- All fittings included

Already have a Beast lock?

Convert it in to a floor lock with this handy adaptor

ADAPTOR



CODE	DESCRIPTION
LK115	Beast Floor Lock
LK113	Beast Floor Lock Adaptor

ANCHORS

DOCKING STATION

Ground / wall anchor with integrated lock

FEATURES

- Fits up to 16mm chains
- Combines the rigidity of an anchor with the flexibility of a chain
- Made entirely from forged hardened steel
- All fittings included



CODE DESCRIPTION

LK401 Docking station



BEAST ANCHOR

High security ground / wall anchor

FEATURES

- Hardened steel double layer construction
- Fits all oxford chains and locks
- 22mm Beast chain compatible
- All fittings included



CODE DESCRIPTION

LK403 Beast Anchor



ROTAFORCE

High security rotating ground anchor

FEATURES

- 26mmø hardened ring
- Rotating head allows easier fitment and better bike positioning
- 59mm internal diameter
- All fittings included



CODE	DESCRIPTION
------	-------------

LK400	Rotaforce
-------	-----------



ANCHORFORCE

High security ground / wall anchor

FEATURES

- Hardened steel double layer construction
- Fits up to 16mm chains
- Designed to resist angle grinder attacks
- All fittings included



CODE	DESCRIPTION
------	-------------

LK404	Anchorforce
-------	-------------



ANCHORS

TERRAFORCE

High security case-hardened steel ground anchor

FEATURES

- 24mmø hardened ring
- Simple concrete-in design
- 54mm internal diameter
- All fittings included



CODE DESCRIPTION

LK402 Terraforce



NEW STRIKEFORCE

High security ground / wall anchor

FEATURES

- Fits up to 16mm chains
- Bolts protected by ball bearings once fitted
- All fittings included



CODE DESCRIPTION

LK409 Strike Force



NEW TASKFORCE

High security ground / wall anchor

FEATURES

- Fits up to 16mm chains
- Folds flat when not in use
- Hardened steel 14mm shackle
- Tough polymer housing
- All fittings included



CODE DESCRIPTION

LK408 Task Force



BRUTEFORCE

High security ground / wall anchor

FEATURES

- Fits up to 14mm chains
- Can be used on floors or walls
- Bolts protected by ball bearings once fitted
- All fittings supplied



CODE DESCRIPTION

LK397 Bruteforce





DISC LOCKS

BOSS ALARM

Ultra strong alarm lock



FEATURES

- Choice of 14mm and 16mm hardened steel shackles
- Very loud 100dB alarm
- Anti-jack design can withstand 4.5 tonnes of tensile load
- Can be used with or without removable, sealed unit alarm module

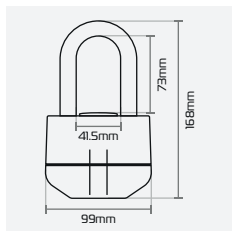

CODE	DESCRIPTION
OF3	Boss Alarm 14mm - Yellow
LK484	Boss Alarm 16mm - Black



ALPHA XA14

Super strong alarm disc lock



FEATURES

- 14mm hardened locking pin
- Very loud 110dB alarm
- Forged stainless steel construction
- Rechargeable lithium polymer battery (USB cable included)

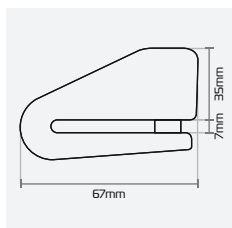

CODE	DESCRIPTION
LK217	Alpha XA14 - Yellow
LK218	Alpha XA14 - Black



DISC LOCKS

QUARTZ XA10 + XA6

High security alarm disc locks

FEATURES

- 10mm or 6mm hardened locking pin
- Very loud 110dB alarm
- Twin spar lock chassis for double strength and cut resistance
- Rechargeable lithium polymer battery (USB cable included)
- Push to lock



110dB

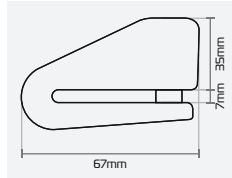

CODE	DESCRIPTION
LK216	Quartz XA10 - 10mm
LK215	Quartz XA6 - 6mm

MICRO XA5

High security alarm disc lock

FEATURES

- 5mm hardened locking pin
- Very loud 110dB alarm
- Universal fitment for all scooters
- Rechargeable lithium polymer battery (USB cable included)
- Minder cable included
- Push to lock



110dB

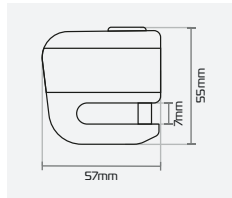

CODE	DESCRIPTION
LK213	Micro XA5 - Yellow
LK214	Micro XA5 - Black

SCREAMER 7

Attack activated alarm disc lock

FEATURES

- 7mm hardened locking pin
- Very loud 100dB alarm
- Motion and shock sensors
- Powered by a lithium CR2 long life battery



100dB

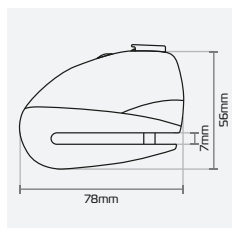

CODE	DESCRIPTION
LK290	Screamer XA7 - Yellow
LK289	Screamer XA7 - Black

NEMESIS

Ultra strong disc lock

FEATURES

- 16mm hardened shackle
- Shock resistant rubber over-moulding
- Anti-pick and anti-drill lock cylinder
- Double locking mechanism

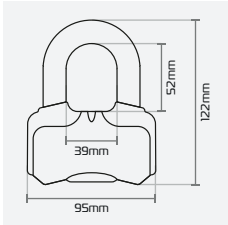

CODE	DESCRIPTION
------	-------------

LK471	Nemesis
-------	---------

MONSTER

Ultra strong disc lock

FEATURES

- 11mm hardened & concealed shackle
- Widened access to fit even the largest discs
- Double locking mechanism
- Built-in lock cylinder dust cover

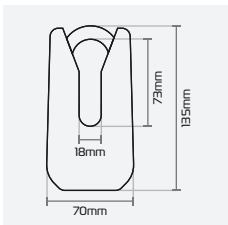

CODE	DESCRIPTION
------	-------------

OF36M	Monster
-------	---------

PATRIOT

Ultra strong disc lock

FEATURES

- 14mm hardened rotating locking pin
- 4 way locking system
- By design the lock body is protected within brake discs
- Compact, so convenient to transport

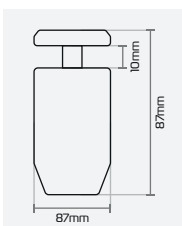

CODE	DESCRIPTION
------	-------------

OF40	Patriot
------	---------



DISC LOCKS

ALPHA XD14

Super strong disc lock

FEATURES

- 14mm hardened locking pin
- Double locking mechanism
- Forged stainless steel construction



CODE	DESCRIPTION
LK275	Alpha XD14 - Black
LK276	Alpha XD14 - Yellow



BOSS

Super strong disc lock

FEATURES

- Hardened shackle
- Anti-pick & anti-drill lock cylinder
- Double locking mechanism
- Hardened steel armour casing

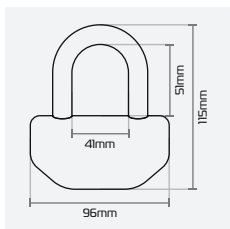

CODE	DESCRIPTION
OF39	Boss - 12.7mm
OF46	Boss - 16mm



QUARTZ XD10 + XD6

High security disc lock

FEATURES

- 10mm or 6mm hardened locking pin
- Includes minder cable and attachment eye
- Twin spar lock chassis for double strength and cut resistance
- Compact - Convenient to carry on bike or in a bag
- Push to lock

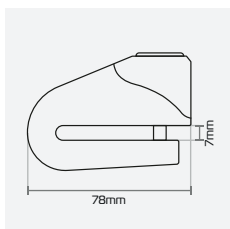

CODE	DESCRIPTION
LK209	Quartz XD10
LK207	Quartz XD6



MICRO XD5

High security disc lock

FEATURES

- 5mm hardened locking pin
- Twin spar lock chassis for double strength and cut resistance
- Compact - Convenient to carry on bike or bag
- Push to lock

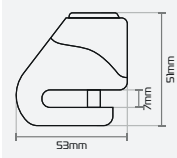

CODE	DESCRIPTION
------	-------------

LK205	Micro XD5
-------	-----------



TITAN

Tough & reliable disc lock

FEATURES

- 10mm hardened locking pin
- Simple push to lock feature
- Convenient carry pouch included
- Built in lock cylinder dust cover

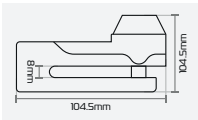

CODE	DESCRIPTION
------	-------------

LK485	Titan - Black
-------	---------------

LK486	Titan - Yellow
-------	----------------



MINI T

Tough & reliable mini disc lock

FEATURES

- 5.5mm hardened locking pin
- Simple push to lock feature
- Built in lock cylinder dust cover
- Carry pouch included

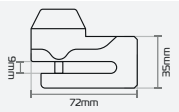

CODE	DESCRIPTION
------	-------------

LK291	Mini T - Yellow
-------	-----------------

LK292	Mini T - Black
-------	----------------



HD MAX

High security disc lock

FEATURES

- 14mm shackle
- Anti-pick & anti-drill lock cylinder
- Double locking mechanism

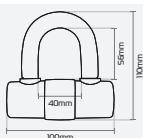

CODE	DESCRIPTION
------	-------------

LK311	HD Max - Yellow
-------	-----------------

LK310	HD Max - Black
-------	----------------

LK312	HD Max - Orange
-------	-----------------





CHAINS



BEAST

Maximum security
22mm link chain

FEATURES

- Oxford's strongest ever chain
- 22mm round links
- Angle grinder resistant
- 12 & 15.5kg weight
- Available in 1.5m & 2.0m lengths



CODE	DESCRIPTION
LK126	Beast - 1.5m
LK127	Beast - 2.0m

ROUND

Ultra strong
16mm link chain

FEATURES

- Ni-Cro-Mo hardened steel
- Long links reduce weight and increase portability
- Available in 1.2m, 1.5m & 2.0m lengths



CODE	DESCRIPTION
OFN12	Round Link - 1.2m
OFN15	Round Link - 1.5m
OFN20	Round Link - 2.0m

HEX

Ultra strong
14mm link chain

FEATURES

- Ni-Cro-Mo steel
- Can be easily stowed under seat
- Available in 1.2m, 1.5m & 2.0m lengths



CODE	DESCRIPTION
OFM12	Hex Link - 1.2m
OFM15	Hex Link - 1.5m
OFM2	Hex Link - 2.0m

SQUARE

High security
12mm link chain

FEATURES

- Ni-Cro-Mo steel
- Can be used with all Oxford ground anchors
- Available in 1.2m 1.5m & 2.0m lengths



CODE	DESCRIPTION
OFH1G	Square Link - 1.2m
OFH15G	Square Link - 1.5m
OFH2G	Square Link - 2.0m

COVERS

OKFORD
PRX STRETCH

OKFORD
Essential Rider Equip

IMPORTANT:

Do not allow this covers to come into contact with hot exhausts, engine parts or sharp objects
Sizes are approximate and may vary dependent on motorbike. If unsure size up.



COVERS CAN HELP
REDUCE THEFT



MP3 PROTEX COVER



REAR WINDOW IN USE

PROTEX STRETCH

Premium outdoor motorcycle cover

FEATURES

- 2 way stretch material provides a snug fit
- Water-resistant seams
- Tough 3-layer material with soft lining protects against weather, light knocks & scratches
- Reflective panels & logos increase visibility at night
- Strategically positioned holes facilitate the use of a lock (front & rear)
- Lock pouches (front & rear) keep your padlock off the ground
- Ventilated to reduce condensation
- Rear window to show number plate (optional use)
- Elasticated bottom & adjustable belly strap to hold the cover in place
- Front inner pocket with PVC window to hold a solar panel charger (Oxford Solariser - see page 48)

"Ranked No.1 by MCN R5K Readers' Top 5 Covers"

MCN

"Packed with features, tough and easy to use, and resists a sustained blast from pressure washer as well as rain."

RIDE

OFFERS PROTECTION AGAINST

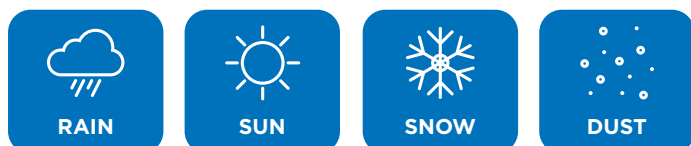

CODE	DESCRIPTION
CV160	Protex Stretch - S
CV161	Protex Stretch - M
CV162	Protex Stretch - L
CV163	Protex Stretch - XL
CV164	Protex Stretch - MP3

Size guide on page 43

COVERS



REAR WINDOW IN USE



STORMEX

Ultimate outdoor motorcycle cover

FEATURES

- Externally bonded seams for maximum rain protection
- Heat resistant lining material in case of momentary contact with exhaust
- Soft lining protects against scratches
- Reflective panels increase visibility at night
- Tough outer protects against weather & knocks
- Strategically positioned holes facilitate the use of a lock with lock pouch helps to keep your padlock off the ground
- Adjustable belly strap holds it in place
- UV colourfast solution dyed fibres
- Wrap around splash protector prevents water from being absorbed up the lining
- Rear window allows the number to be visible, but an internal 'curtain' enables it to be covered
- Front inner pocket with PVC window to hold a solar panel charger (Oxford Solariser - see page 48)

OFFERS PROTECTION AGAINST



"THE ALL -SINGING, ALL-DANCING Oxford cover is the second most expensive product in the test but the highest scorer... It offers serious protection against the elements. The material proved water, abrasion and heat resistant, and should last a good few years."

18/20 1st in test

RIDE

CODE DESCRIPTION

CV330	Stormex - S
CV331	Stormex - M
CV332	Stormex - L
CV333	Stormex - XL

Size guide on page 43

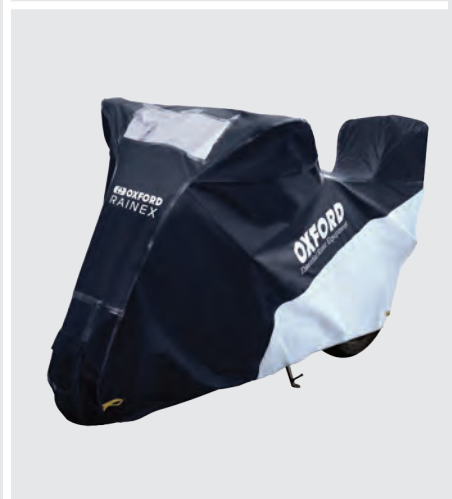

RAINEX

Deluxe outdoor motorcycle cover

FEATURES

- Externally bonded seams for maximum rain protection
- Handlebar air vents to prevent condensation
- Tough outer material protects against weather & knocks
- Soft lining protects against scratches
- Reflective panels increase visibility at night
- Adjustable belly strap holds it in place
- Heat resistant lining material in case of momentary contact with exhaust
- Strategically positioned holes facilitate the use of a lock; lock pouch helps to keep your padlock off the ground
- Front inner pocket with PVC window to hold a solar panel charger (Oxford Solariser - see page 48)

RAINEX TOPBOX

- Fits over all Oxford Top Boxes (OL208 + OL209)

OFFERS PROTECTION AGAINST

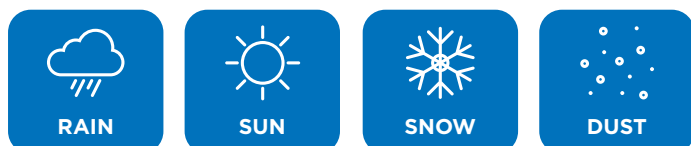

CODE	DESCRIPTION
CV501	Rainex - S
CV502	Rainex - M
CV503	Rainex - L
CV504	Rainex - XL
CV505	Rainex Topbox- S
CV506	Rainex Topbox - M
CV507	Rainex Topbox - L
CV508	Rainex Topbox - XL

Size guide on page 43

COVERS



AQUATEX

Essential outdoor motorcycle cover

FEATURES FOR ALL AQUATEX COVERS

The Oxford Aquatex is THE essential motorcycle/scooter cover. As you would expect from the world's best-selling motorcycle cover it comes packed with useful features and is built to last.

Designed for both outdoor and indoor use, it offers protection against rain and dust. Police initiatives have also shown that bike covers can be a useful theft deterrent. This is especially true if you securely the belly strap in place and use the cover in conjunction with a chain lock, threaded through the lock holes provided, securing both motorcycle and cover in place at the same time.

The UK's most respected motorcycle consumer title Ride Magazine rated the Aquatex BEST BUY in their market review. They praised the combination of weatherproofing, quality construction, useful additional features and incredible value.

OFFERS PROTECTION AGAINST



- Double-stitched polyester for strength and durability
- Complete exterior and interior protection - can be used both as an outdoor rain cover and an indoor dust cover
- An elasticated base with a belly strap creates a snug, secure fit
- Comes with a zipped carrier, to store away compactly when not in use
- Strong but lightweight material is UV resistant, so does not degrade in sunlight
- Double PU coating for optimal waterproofing
- Available in 6 sizes including MP3 and High-screen bikes

"Stocked widely by motorcycle dealers all across the country, this is a lightweight, low-priced and highly effective cover that's easy-to put on and take off."

RIDE

Size guide on page 43



AQUATEX

CODE	DESCRIPTION
CV200	Aquatex - S
CV202	Aquatex - M
CV204	Aquatex - L
CV206	Aquatex - XL



AQUATEX MP3

CODE	DESCRIPTION
CV215	Aquatex - MP3



AQUATEX HIGHSCREEN

CODE	DESCRIPTION
CV216	Aquatex - Highscreen



AQUATEX FLUO

CODE	DESCRIPTION
CV221	Aquatex Fluo - M
CV222	Aquatex Fluo - L
CV223	Aquatex Fluo - XL



AQUATEX CAMO

CODE	DESCRIPTION
CV2211	Aquatex Camo - S
CV212	Aquatex Camo - M
CV213	Aquatex Camo - L
CV214	Aquatex Camo - XL



AQUATEX TOPBOX

CODE	DESCRIPTION
CV201	Aquatex Topbox - S
CV203	Aquatex Topbox - M
CV205	Aquatex Topbox - L
CV207	Aquatex Topbox - XL
CV217	Aquatex Topbox - Highscreen

COVERS

AQUATEX ATV

Essential outdoor ATV cover

FEATURES

- Double-stitched Polyester for strength and durability
- Complete exterior and interior protection
- Elasticated bottom for a snug fit
- Double PA coating
- Complete with carry case, to store away compactly when not in use

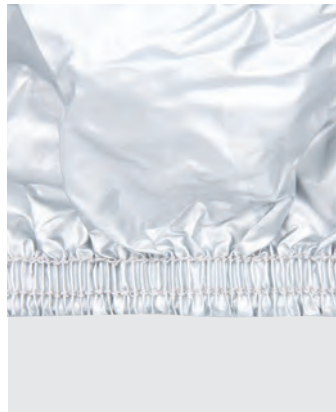

CODE	DESCRIPTION
CV208	Aquatex ATV - S
CV209	Aquatex ATV - M
CV210	Aquatex ATV - L

UMBRATEX

Essential outdoor motorcycle cover

FEATURES

- Covers the top half of the bike to ensure your seat and controls are kept dry
- Packs down small enough to fit under most motorcycle seats or inside your motorcycle luggage / backpack
- Supplied with easy to use fitting straps



CODE	DESCRIPTION
CV106	Umbratex - M
CV107	Umbratex - L
CV108	Umbratex - XL



SCOOTSEAT

Universal scooter seat cover

FEATURES

- Waterproof cover
- Elasticated bottom to allow a snug fit
- Convenient storage case
- Can be secured against theft: simply lock the pouch under the seat
- Size guide on page 43



CODE DESCRIPTION

CV185	Scoot seat - S
CV186	Scoot seat - M
CV187	Scoot seat - L

SCOOTLEG

Universal scooter leg cover

FEATURES

- Waterproof construction with thermal insulation
- Secures to scooter via 'hook-and-loop' fastening
- Fits to the rider using safety buckles with detachable bib
- Reflective printing on the sides
- Convenient storage case
- Lock eyelets for securing whilst parked



CODE DESCRIPTION

CV399	Scootleg
-------	----------

COVERS

PROTEX STRETCH

Premium stretch-fit indoor cover

FEATURES

- 4-way stretch
- Breathable material to avoid condensation/moisture retention and the resulting risk of rust
- Soft lining protects paintwork from minor bumps
- Elasticated base with adjustable belly strap to secure in place
- Four sizes available

OFFERS PROTECTION AGAINST



CODE	DESCRIPTION	CODE	DESCRIPTION	CODE	DESCRIPTION
CV170	Black - S	CV174	Red - S	CV178	Blue - S
CV171	Black - M	CV175	Red - M	CV179	Blue - M
CV172	Black - L	CV176	Red - L	CV180	Blue - L
CV173	Black - XL	CV177	Red - XL	CV181	Blue - XL



DORMEX

Essential indoor motorcycle cover

FEATURES

- Breathable dust cover for indoor use
- Eliminates dust which can scratch paintwork
- Breathable membrane that allows the air to constantly travel through
- Elasticated bottom and belly strap to allow a snug fit

OFFERS PROTECTION AGAINST



CODE	DESCRIPTION
CV401	Dormex - S
CV402	Dormex - M
CV403	Dormex - L
CV404	Dormex - XL



COVER SIZE GUIDES

PROTEX STRETCH, STORMEX, RAINEX, AQUATEX & DORMEX (CM)

SIZE	LENGTH	FRONT WIDTH	FRONT HEIGHT	REAR WIDTH	REAR HEIGHT	SCREEN WIDTH
SMALL	203	83	119	35	80	-
MEDIUM	229	99	125	35	90	-
LARGE	246	104	127	35	92	-
EXTRA LARGE	277	104	141	35	102	-
MP3 / 3 WHEEL SCOOTER	220	77.5	130	45	92	-
HIGHSCREEN	203	83	184	184	35	55

RAINEX TOPBOX & AQUATEX TOPBOX (CM)

SIZE	LENGTH	FRONT WIDTH	FRONT HEIGHT	REAR WIDTH	REAR HEIGHT	SCREEN WIDTH
SMALL	203	83	119	35	112	-
MEDIUM	229	99	125	48	127	-
LARGE	246	104	127	48	130	-
EXTRA LARGE	277	104	141	57	135	-
HIGHSCREEN	203	83	184	35	112	55

SCOOT SEAT (CM)

SIZE
SMALL - 100 x 65
MEDIUM - 120 x 75
LARGE - 145 x 104

Sizes are approximate and may vary dependant on motorbike. If unsure size up.



BATTERY CARE

THE IDIOT'S GUIDE TO THE OXFORD OXIMISER 3X AND OXIMISER 900

Attach to your battery and it will charge until the battery has reached full capacity and thereafter ensure that it is kept in tip-top condition. If the battery is deeply discharged it will recover it with a varying charge rate and then it never drops below the critical voltage level of 12.6V. The digital displays and battery level indicators keep you informed every step of the way. They are suitable for use on a variety of vehicle batteries - see guidance below.

NOTE: If a battery is left discharged for even a short period of time and remains under 11.9V, permanent damage will occur and even the smartest battery charging methods are unlikely to recover the battery to a useable condition.

BATTERY CHARGER KEY



Polarity Check

Checks the battery leads have been connected correctly



Bulk Fast Charge

Charges at a fast rate to bring the battery to approximately 85% capacity



Battery Condition

LED lights indicate a weak or strong battery



Battery Analysis

Assesses battery & determines best charging method



Absorption Charge

Lowers the charge rate & gives a topping charge to ensure the battery is charged to 100%

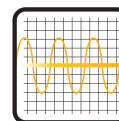

Float Charge

Applies a small float charge current to ensure the battery voltage and condition remain optimised



Soft Start Charge

Controlled build up of charge current ensuring discharged batteries are charged safely



Voltage Check

Hourly voltage checks assess battery health

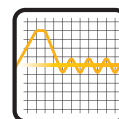

Maintain Mode

Applies an appropriate charge if voltage drops outside acceptable limits to ensure the battery voltage and condition remains perfect



OXIMISER 3X

Advanced battery management system

The Oximiser 3X is Oxford's most versatile, most powerful, multi-purpose battery maintenance product. It offers not one, but THREE automated charging programs for differing battery sizes - perfect for bikes, cars, even leisure batteries! So, if you have multiple toys in your garage, it's the only battery optimiser you are ever likely to need. LCD display provides a wealth of information so that you know what it is doing at all times

8 STAGE BATTERY MANAGEMENT CHARGE PROGRAMS:

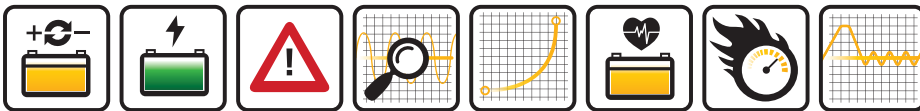

3 SELECTABLE CHARGE POWER MODES:

BIKE
UP TO
800mA
14.4V

BIKE / CAR
UP TO
3600mA
14.4V

WINTER
UP TO
3600mA
14.7V

SUITABLE FOR USE WITH VARIOUS BATTERY TYPES UP TO 125AH CAPACITY:

LEAD ACID ✓
GEL ✓ AGM ✓

LITHIUM ✓

PARTS INCLUDED



Battery Clamps

6mm Ring Leads

FEATURES

- Designed and tested in the UK using top quality long-life components
- A 2 year warranty is included as standard
- A 'soft-start' charging mode to improve recovery of deeply discharged batteries as low as 8 volts
- Intelligent charging will 'cycle-charge' in an attempt to recover sulphated batteries
- Suitable for all 12V automotive batteries including LITHIUM lifePO4 motorcycle batteries
- New voltage sensors quickly detect high current drain and will automatically revert to the most appropriate charge rate
- Soft touch rubberised case for improved grip and ruggedness
- Wall bracket included

CODE	DESCRIPTION
EL200	Oximiser 3X - UK
EL200AU	Oximiser 3X - AU/NZ
EL200EU	Oximiser 3X - Europe
EL200JPD	Oximiser 3X - Japan
EL200USD	Oximiser 3X - USA/ Canada

BATTERY CARE



OXIMISER 900

Essential battery management system

Oximiser 900 can be left permanently connected to provide guaranteed long term battery care. Suitable for all 12V battery types up to 30Ah, including Gel, MF and Acid batteries. Heavily discharged batteries as low as 4.1V can be charged if the battery is not damaged. LCD display provides a wealth of information so that you know what it is doing at all times

6 STAGE BATTERY MANAGEMENT CHARGE PROGRAMS:



SINGLE CHARGE POWER MODE:

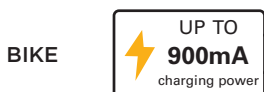

SUITABLE FOR USE WITH VARIOUS BATTERY TYPES UP TO 30AH CAPACITY:



FEATURES

- 1 Ventilation
- 2 Charge status - shows charging activity
- 3 Battery level indicator - displays battery status
- 4 Battery voltage and amp meter
- 5 Power indicator button
- 6 Connection warning - checks for correct polarity
- 7 Back-lit display - back light activation
- 8 Wall bracket included

PARTS INCLUDED



Battery Clamps

6mm Ring Leads

CODE	DESCRIPTION
EL570	Oximiser 900 - UK
EL571	Oximiser 900 - Europe
EL571AD	Oximiser 900 - AU/NZ
EL571SAD	Oximiser 900 - South Africa
EL571USD	Oximiser 900 - USA/Canada



OXIMISER 601

Essential battery optimiser

A modern charger designed to charge, optimise and prolong the life of a 12V automotive battery. It uses a continuous yet variable charge current to ensure that the battery is charged correctly. If a load is applied to the battery, this charger will compensate by automatically increasing the charge current and thereby maintain the battery condition. It can be used with most batteries including Maintenance Free and Gel types. It is ideally suited for charging batteries ranging in size from 4Ah - 30Ah. This covers batteries normally fitted to scooters, motorcycles, golf trolleys, light aircraft, ride-on lawn mowers and small (such as classic/racing) cars.

3 STAGE BATTERY MANAGEMENT CHARGE PROGRAMS:



SINGLE CHARGE POWER MODE:

BIKE

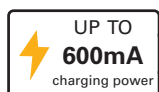

SUITABLE FOR USE WITH VARIOUS BATTERY TYPES UP TO 30AH CAPACITY:

LEAD ACID ✓

GEL ✓

AGM ✓

LITHIUM ✓

PARTS INCLUDED



Battery Clamps

6mm Ring Leads

FEATURES

- 1 Ventilation
- 2 Battery connection/ polarity error indicator
- 3 LED charge voltage indicator
- 4 Dead battery indicator
- 5 Continuous float charge
- 6 Wall bracket included

Oximiser 601 can be left permanently connected to provide guaranteed long term battery care.

- Recovers deeply discharged batteries
- Protected against short circuit
- 2 year guarantee

WARNING: Not suitable for 6V or 24V batteries. Protected against short circuits. For 240V

CODE	DESCRIPTION
EL600	Oximiser 601 - UK
EL600EU	Oximiser 601 - Europe
EL601AD	Oximiser 601 - AU/NZ

BATTERY CARE



SOLARISER

Essential solar battery optimiser

The Solariser is a solar battery charger for maintaining 12V Automotive batteries all year round. Amorphous solar technology can produce output in most lighting conditions. There is no need for direct sunlight as the charger will operate using just daylight. It is ideal for vehicles left outside or in remote lock-ups where the Solariser can be left outside or attached to a window or garage roof, perfect for where there is no mains power source.

FEATURES

- 1.8 Watt Solar battery charger for maintaining 12V automotive batteries all year round
- Perfect for where there is no mains power source
- Ideal for vehicles left outside or in remote lock-ups where the Solariser can be left outside or attached to a window or garage roof
- LED light shows battery will charge with available light
- Operates in extreme temperatures -20°C to 100°C
- Trickle-charge current between 10mA - 100mA
- Weatherproof connectors
- Size (approx): 250 x 180 x 12 mm

SUITABLE FOR USE WITH VARIOUS BATTERY TYPES UP TO 30AH CAPACITY:

BIKE

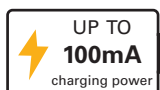

PARTS INCLUDED



Cigarette lighter charger

Battery clamps

6mm ring leads

CODE	DESCRIPTION
OF949	Solariser
OF949L12 (2012>)	3m ext lead



DUAL PORT USB CHARGER

1.2m

FEATURES

- Weatherproof Dual USB Power supply socket for fitment to motorcycles, ATVs, Snow mobiles, etc
- Enables charging multiple devices by USB lead (not included)
- High output (2 Amps) will charge ipads, iphones etc
- Heavy duty weatherproof cap keeps the insides dry
- Designed for 22-25mm handlebar mounting but can also be mounted on the mirror stem using the unique adapters provided
- Can be panel mounted if required by removing the outer bracket

CODE
EL102



USB 2.1 AMP

Fused power charging kit

FEATURES

- Suitable for devices such as phones, tablets and sat navs
- Powered from a 12V battery system of a car, motorcycle, boat etc. using an Oxford lead kit
- Robust construction suitable for outdoor use
- The unit must be used with the (2 amp min) fused battery harness included or directly to your existing battery charger lead connector
- Splash-resistant silicone cap protects internal parts
- High quality components and short circuit protection
- Optional adapter included for conversion to US style battery harnesses

CODE
EL114



12V SOCKET

1.2m

FEATURES

- Weatherproof 12V Power supply socket for fitment to motorcycles, ATVs, snow mobiles, etc
- Enables use of devices with a standard 12V socket (21mm \varnothing)
- Heavy duty weatherproof cap keeps the insides dry
- Designed for 22-25mm handlebar mounting but can also be mounted on the mirror stem using the unique adapters provided
- Can be panel mounted if required by removing the outer bracket
- Maximum output 120W / 10 Amps

CODE
EL101



12V DIN SOCKET

1.2m

FEATURES

- Weather-resistant 12V Din socket for motorcycles (standard on BMW), ATVs, snowmobiles, etc
- Enables the use of din plugs such as those found on battery chargers, heated clothing, etc
- Compatible with the Oxford plug lead (OF704)
- Compact thread diameter (18mm \varnothing) is designed for panel mounting
- Maximum output 120W / 10 A

CODE
EL100

BATTERY ACCESSORIES



Removable adapter cap



12V ACCESSORY PLUG

- Alternative USA/SAE connector available
- Weather resistant fuse holder

CODE	TYPE
OF704	Reg - 3m
EL106	SAE - 0.5m

PERMANENT CONNECTOR

- Alternative USA/SAE connector available for 6mmØ bolts

CODE	TYPE
OF703	Reg - 0.5m
EL105	SAE - 0.5m



Removable adapter cap

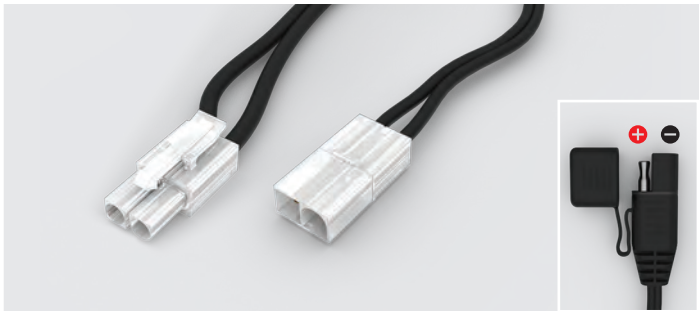

CROCODILE CLIPS

Alternative USA/SAE connector available

CODE	TYPE
OF702	Reg - 0.5m
EL104	SAE - 0.5m

EXTENSION CABLE

Alternative USA/SAE connector available

CODE	TYPE
OF705	Reg - 3m
EL108	SAE - 3m



OXIMISER TO SAE CONNECTOR

CODE	TYPE
EL103	Oximiser - SAE



SAE TO OXIMISER CONNECTOR

CODE	TYPE
EL109	SAE - Oximiser



SAE EXTENSION CABLE

CODE	TYPE
EL110	SAE - 1.5m



HOTGRIPS™ / OXIMISER

- Permanent connector
- Weather resistant fuse holder

CODE	TYPE
OF695L	Regular

ZERO-G

PADDOCK STANDS



NET WEIGHT: APPROX 4.0 KG
MAX WIDTH: 200mm
MIN WIDTH: 230mm
MAX LOAD: 200KG

OXFORD PADDOCK STANDS

We have been producing the industry's best paddock stands for well over a decade now.

Independent product tests - be it MCN 5-star reviews or RIDE 'BEST BUY' triangles - always yield top marks for stability, ease of use and quality of construction.

More importantly, we enjoy thousands of positive customer views posted on-line, which we scan for ideas on how we might improve our products.

As we set about developing the next generation of Oxford paddock stands, we brought together all of this experience and feedback and created something really very special ... **ZERO-G**.

ENGINEERED TO TAKE THE WEIGHT OFF...

All of our paddock stands are engineered using the latest CAD technology and 3D modelling techniques. By being scientifically designed to minimise the required effort to move a given load, our new ZERO-G range of paddock stands literally take the weight off. Even better, they are able to do this without weighing too much themselves, making them even easier to use and live with.

In fact, they are on average 70% more rigid than previous models, whilst weighing 35% less.

TESTED TO EXTREMES...

The entire range of products was subjected to the rigours of our test laboratory. In the case of ZERO-G paddock stands, the components had to survive our accelerated weathering simulator and then prove themselves in our 5000kg tensile machine, before being tested in real world conditions.

The average bike weighs 210kg, split 60/40 front to rear. That means that a rear paddock stand has to withstand on average 84kg.

Just for fun (because most aren't even paddock stand compatible), the heaviest production bikes in the world weigh over 400kg, meaning that a rear paddock stand would need to be able to deal with 160kg.

ZERO-G paddock stands are all rated to 300kg, but this is with a HUGE safety margin; in our tensile tester, all test examples have withstood at least 1800kg.



CHOICES, CHOICES, CHOICES...

ZERO-G paddock stands cater for all kind of bikes - including those with single-sided swing arms - and preferences, such as a choice of fork- or headstock-mounted front stands.

If you are dashing up and down the pitlane, you'll probably choose our aluminium ZERO-G LITE stands for their minimal 4kg weight. PITLANE PERFECTION.

If you're regularly fettling your pride-and-joy, you might prefer the reassurance of our steel ZERO-G stands. DREAM WORKSHOP.

If you're on a budget or have limited use for stands, you'll also find our brilliant 'standard' paddock stands at the back this brochure, along with all the accessories you might need. HOME MECHANIC.

Whatever your needs, we have the paddock stand solution.

MAKING LIFE ON TWO WHEELS BETTER.





Cadwell Park

cadwellpark.co.uk

Cadwell

Cadwell Park

cadwellpark.co.uk

Cadwell Park

IDP

OXFORD

NET WEIGHT APPROX 4.6KG
MAX WEIGHT 20kg
MIN WEIGHT 2.5kg
MAX LOAD 200KG



Pitlane
PERFECTION

cadwellpark.co.uk

Cadwell Park

cadwellpark.co.uk

cadwellpark.co.uk

cadwellpark.co.uk

OXFORD

NET WEIGHT APPROX 4.6KG
MAX WIDTH 150mm
MIN WIDTH 28mm
MAX LOAD 30KG

ZERO-G LITE

LIGHTWEIGHT ALUMINIUM Paddock STANDS



FRONT
OX285



REAR
OX284



Lightweight aluminium construction



Heavy duty fasteners



Oversized for increased stability

FEATURES:

- Square tubing to prevent rotation
- Angled handle for more leverage and a controlled lift
- Included: Front stand forks (front OX291), Bobbin forks (rear OX290)
- Fork lock-off screws for secure fitment
- Robot welded for high build quality and consistency





MATERIAL:
Aerospace 6063-T5
grade aluminium

MAX LOAD:
300kg

STAND WEIGHT:
4kg

LIFT HEIGHT:
300mm (Pin Centre)

OXFORD

NET WEIGHT: APPROX 4.8KG
MAX WIDTH: 350mm
MIN WIDTH: 250mm
MAX LOAD: 300KG





Dream
WORKSHOP

CALIFORNIA
SUPER
SCHOOL

30

ABS

OXFORD

WITH BRIGHT ANTI-ROCK LING
BALL BEARING LING
IMPROVED SWAY
BALL BEARING LING

OXFORD

ZERO-G

Paddock Stands



FRONT
OX264



REAR
OX263



Durable steel construction



Heavy duty fasteners



Large wheels for increased stability

FEATURES:

- Oval tubing to prevent rotation
- Torsional supports for increased stability
- Billet aluminium top cap for tight interface with lifting forks
- Robot welded for high build quality and consistency
- U-Lifters included (OX263)





MATERIAL:
Steel

MAX LOAD:
300kg

STAND WEIGHT:
5.8kg

LIFT HEIGHT:
335mm (Pin Centre)



NET WEIGHT: APPROX 5.9KG
MAX WIDTH: 230mm
MIN WIDTH: 180mm
MAX LOAD: 250KG

ZERO-G

HEADSTOCK Paddock STAND



OX265



Durable steel construction



Heavy duty fasteners



Large wheels for increased stability

FEATURES:

- Oval tubing to prevent rotation
- Torsional supports for increased stability
- 5 lifting pins included
- Rubber sleeve to protect headstock
- Robot welded for high build quality and consistency
- 5 pins included (13 - 18mm)

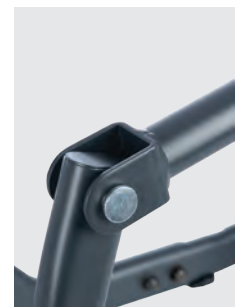



MATERIAL:
Steel

MAX LOAD:
250kg

STAND WEIGHT:
9kg

ZERO-G

SINGLE SIDED Paddock STAND



OX266



Durable steel construction



Heavy duty fasteners



Large wheels for increased stability

FEATURES:

- Oval tubing to prevent rotation
- Torsional supports for increased stability
- Integrated bearings for smooth lifting
- Billet aluminium pins available separately
- Robot welded for high build quality and consistency



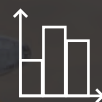

MATERIAL:
Steel

MAX LOAD:
300kg

STAND WEIGHT:
6.7kg

LIFT HEIGHT:
350mm (Pin Centre)

ZERO-G

ACCESSORIES

STAND PINS

LIFTING PINS FOR OX266 (BEARINGS INCLUDED)

PIN 1 - 21.5mm

OX267

PIN 2 - 24.5mm

OX268

PIN 3 - 25.5mm

OX269

PIN 4 - 27.5mm

OX270

PIN 5 - 28.5mm

OX271

PIN 6 - 30.5mm

OX272



ZERO-G L-CUPS

REAR LIFTING CUPS FOR USE WITH
ZERO-G LITE, ZERO-G
& PADDOCK STANDS

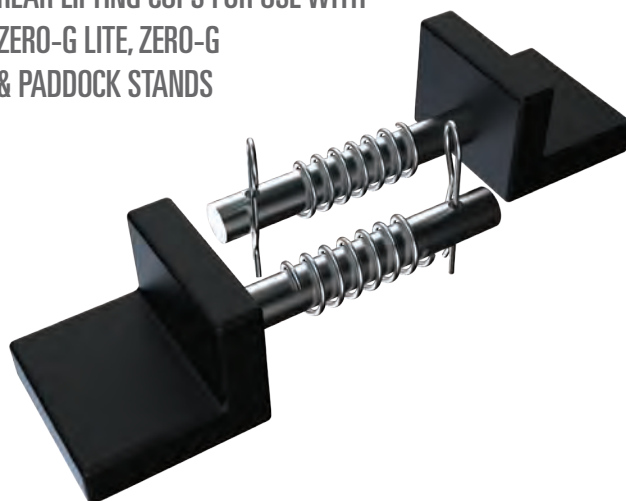

OX289

PIN 7 - 31.5mm

OX273

PIN 8 - 38.5mm

OX274

PIN 9 - 40.5mm

OX275

PIN 10 - 42.5mm

OX276

PIN 11 - 52mm

OX277

PIN 12 - 53.5mm

OX278



ZERO-G BOBBIN FORKS

REAR BOBBIN FORKS FOR USE WITH ZERO-G LITE,
ZERO-G & PADDOCK STANDS



OX290

ZERO-G STAND FORKS

FRONT LIFTING FORKS FOR USE WITH ZERO-G LITE,
ZERO-G & PADDOCK STANDS

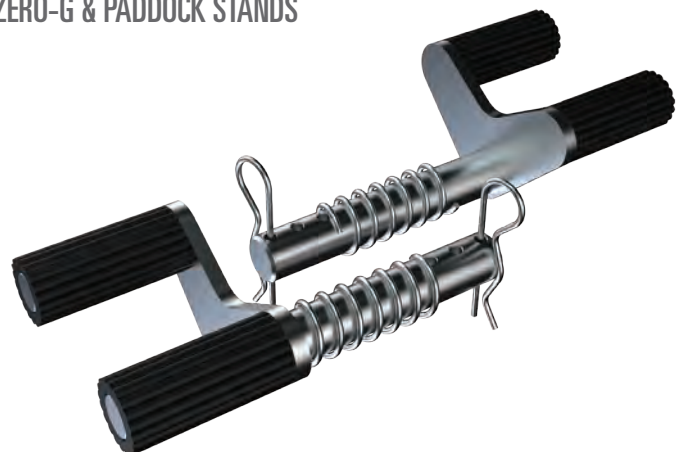

OX291

PADDOCK STANDS



FRONT
OX287



REAR
OX286



Durable steel construction



Heavy duty fasteners



Double wheels for maximum stability

FEATURES:

- Heavy duty fasteners for maximum rigidity
- Torsional supports for increased stability
- Double wheels for smooth lift and maximum stability under load





MATERIAL:
Steel

MAX LOAD:
300kg

STAND WEIGHT:
4.9kg

LIFT HEIGHT:
Front 315mm (Pin Centre)
Rear 324mm (Pin Centre)





PREMIUM PADDOCK STANDS

For wheels up to 17"

A compact frame construction makes them very rigid and very stable. At the same time, an elongated handle provides excellent leverage, so lifting your bike requires minimum effort.

Their powerful construction makes these stands suitable for the widest possible range of applications - from lightweight to big bikes - and rear stands come with both L-shaped cups for swing arms and forks for bobbins.

The stand comes with free Oxford Clean Grips. You can attach them to the stand for comfortable lifting and then attach them to your handlebar grips before starting maintenance.

FEATURES

- Ultra strong frame. Compact construction with 38mmØ tubular steel frame for ultimate stiffness
- Heavy duty steel clamps for maximum rigidity
- High quality double wheels for smooth lift and maximum stability under load

FRONT

- Rubber coated pins for fitting to front forks
- One simple fitting system included
- 2 position adjustment screws ensure security and stability

REAR

- Rubber coated L-cups for straight swing arms
- Forks for use with frame bobbins (bobbins sold separately)
- 2 position adjustment screws ensure security and stability

CODE	DESCRIPTION
OX281	Premium Paddock Stand - Rear
OX282	Premium Paddock Stand -Front
OF821F	Rear Stand - Spare L-Cups



BIG BLACK BIKE Paddock STANDS

For wheels up to 17"

The Oxford Big Black Bike Paddock Stand is exactly as its name suggests. Available as both front and rear stand. The front stand has universal lifting forks whilst the rear has universal L-Cups.

FEATURES

- Fully adjustable padded swing arm rests
- Robust construction using 32/35mmØ steel tube
- 4 chunky wheels for maximum stability



CODE	DESCRIPTION
SP822	Big black bike paddock stand - Front
SP821	Big black bike paddock stand - Rear

BOBBINS & FRAME FORKS

Paddock stand accessories

FEATURES

- Makes fitting a rear paddock stand to your bike much easier and quicker
- Does not mark the bike's swingarm
- The majority of bikes have pre-threaded holes in their swingarms to fit bobbins (consult your bike manufacturer for the bolt and thread size required for your bike)
- Some bikes have uneven swingarms, making the use of bobbins the only way to safely fit a rear paddock stand



CODE DESCRIPTION

OX785	Bobbins M12 (1.25 thread)
OX786	Bobbins M10 (1.5 thread)
OX787	Bobbins M10 (1.25 fine)
OX788	Bobbins M8 (1.25 thread)
OX789	Bobbins M8 (1.25 thread) with integrated spacer
OX790	Bobbins M8 (1.0 thread)
OX791	Bobbins M6 (1.0 thread)
OF828	Bobbins M8 (1.0 fine)
OX784	Fork Supports



NOTE: Frame Forks must be fitted to the rear paddock stand before bobbins can be used.

SPINNERS

Rotating paddock stand accessories

Bobbins make fitting a rear paddock stand to your bike much easier and quicker. Does not mark a bikes swingarm. The majority of bikes have pre-threaded holes in their swingarms to fit bobbins (consult your bike manufacturer for the bolt and thread size required for your bike). Some bikes have uneven swingarms, making the use of bobbins the only way to safely fit the rear paddock stand.

FEATURES

- Lightweight anodised alloy bobbin with bearing
- Stainless steel bearing provides a smooth transition making Spinners the easiest / safest way to use a paddock stand
- Quick simple installation onto the frame / swing arm

Download/view a full compatibility chart at:
www.oxfordproducts.com



CODE DESCRIPTION COLOUR

OX810	Spinners M10 (x1.5)	Black
OX811	Spinners M10 (x1.25)	Black
OX812	Spinners M8 (x1.25)	Black
OX813	Spinners M8 (extended)	Black
OX814	Spinners M8 (x1.0)	Black
OX815	Spinners M6 (x1.0)	Black
OX724	Spinners M12 (x1.25)	Black

CODE DESCRIPTION COLOUR

OX824	Spinners M12	Silver
OX825	Spinners M10	Silver
OX826	Spinners M10 (x1.25)	Silver
OX828	Spinners M8 (x1.0)	Silver
OX829	Spinners M6	Silver



BIKE DOCK

For wheels up to 22"

The Bike Dock secures the front wheel of a motorcycle to keep it upright when being stored or being transported.

FEATURES

- Multi-position pivoting head to provide the best support for the front wheel
- Hoop to attach optional lock (sold separately)
- Dock can be used free standing, screwed to the floor or to trailer
- Slot for attaching additional wheel support strap (not included)
- Heavy duty rubber feet
- Robust steel construction
- Fully adjustable cradle to fit most motorcycles with 12"-22" front wheel

CODE	DESCRIPTION
OX781	Bike Dock

NEW ZERO-G GEAR TIDY

Motorcycle equipment storage system

FEATURES

- Ventilated helmet shelf
- Ventilated glove shelf
- Disc lock mount
- Hanger slots
- Key/ Carabiner hooks
- Fittings included

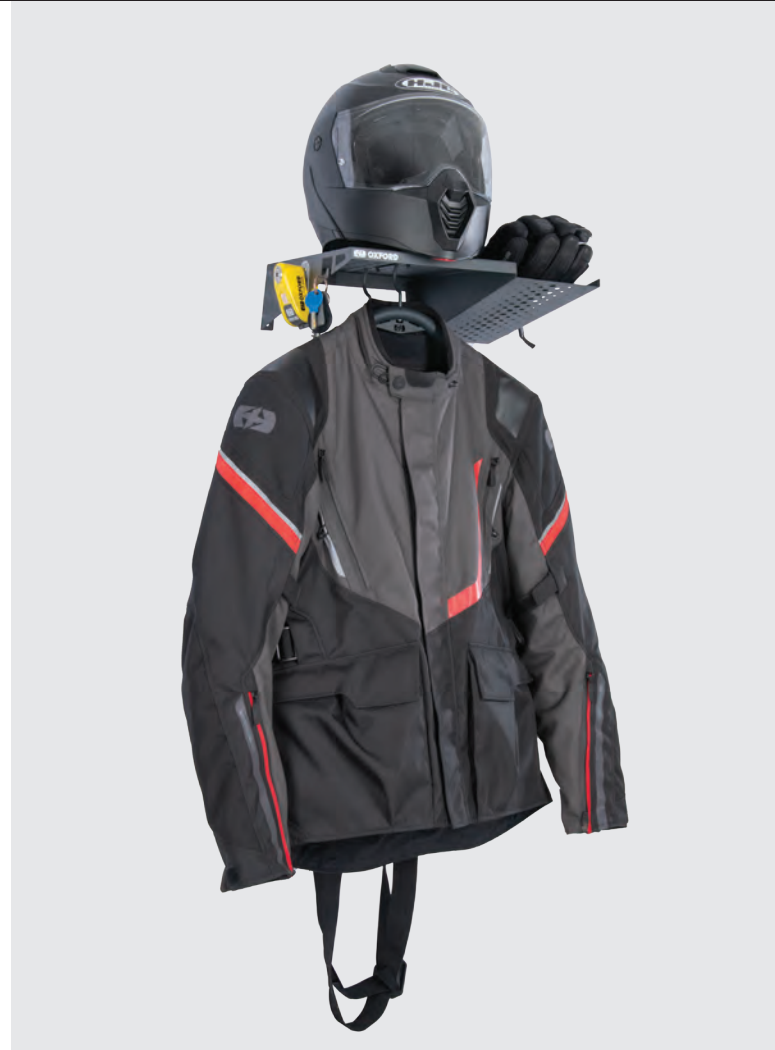

CODE	DESCRIPTION
OX693	Gear Tidy

NEW ZERO-G HANGER

Heavy duty motorcycle gear hanger

FEATURES

- 360° rotating hook
- Robust steel construction
- Max load: 25kg
- Trousers hooks



CODE	DESCRIPTION
OX694	Heavy Duty Hanger

NEW FUEL FLASK

Emergency fuel carrier

FEATURES

- Leakproof seal
- Lightweight aluminium
- Tough and durable construction
- 1.5L: 320 x 88mm
- 1L: 270 x 80mm
- Use with Bottle Stash



CODE	DESCRIPTION
OX835	Fuel Flask - 1L
OX834	Fuel Flask - 1.5L



NEW BOTTLE STASH

Drinks and fuel bottle carrier

FEATURES

- 4 fixing straps
- Molle webbing mounting points
- Durable 600D polyester construction
- Max bottle size: 88mmø x 320mm

CODE	DESCRIPTION
OX837	Bottle stash



NEW AQUA FLASK

Insulated water bottle

FEATURES

- Insulation to keep contents hot or cold
- 1L capacity
- Leakproof seal
- Stainless steel construction
- Use with Bottle Stash



CODE	DESCRIPTION
OX836	Aqua 1.0L insulated flask





WORKSHOP MATS

Fluid resistant floor protectors

DEEP NYLON PILE CARPET:
Captures oil and water spillages
Comfortable to kneel on when working

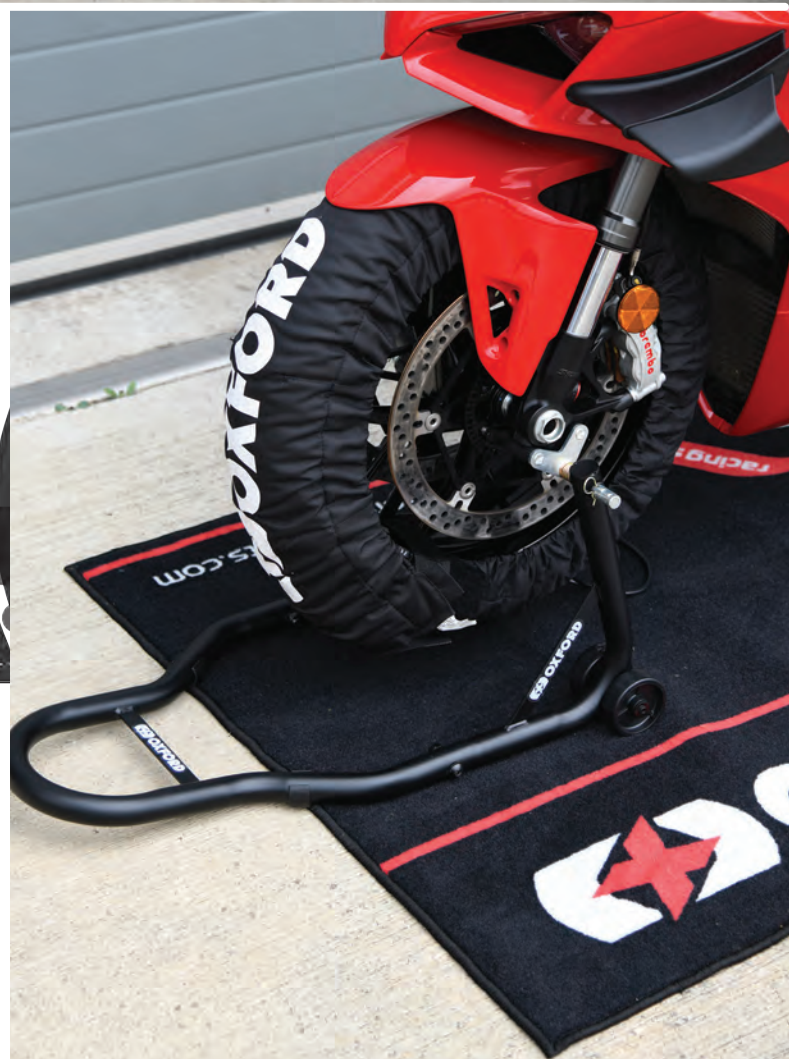
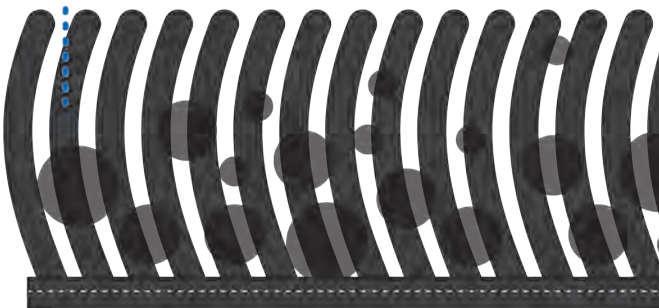

XXL

FEATURES

- Sewn edge to hold back spills
- Hard wearing polyester
- 5mm deep pile carpet
- Size: 250x100cm
- Fluid resistant TPR backing
- Track compliant (meets FIM requirements)

CODE	DESCRIPTION
OX920	Zero-G XXL 250 x 100cm



XL

FEATURES

- Anti-trip edge
- Hard wearing nitrile rubber
- 5mm deep pile carpet
- Size: 240 x 103cm
- Anti-slip nitrile rubber backing
- Track compliant (meets FIM requirements)

CODE	DESCRIPTION
OX662	Racing team mat



M

FEATURES

- Sewn edge to hold back spills
- Hard wearing
- 3mm deep pile carpet
- Size: 80 x 190cm
- TPR backing

CODE	DESCRIPTION
OX661	Motorcycle mat - Oxford





Pitlane Red

Pitlane Yama Blue

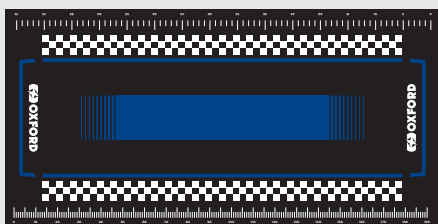

Pitlane Suzi Blue

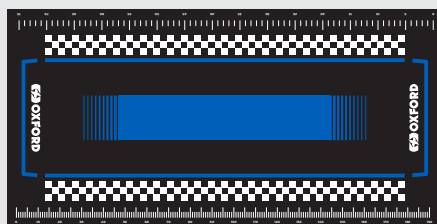

Pitlane Green

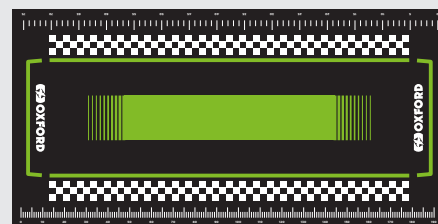

Pitlane Orange

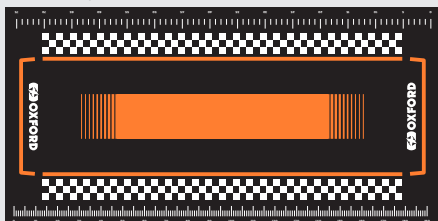

Flame



Adventure



Cafe

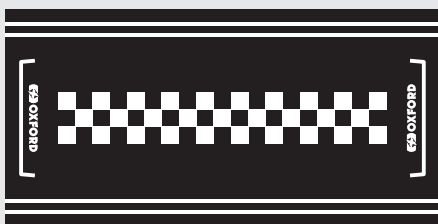

Scrambler

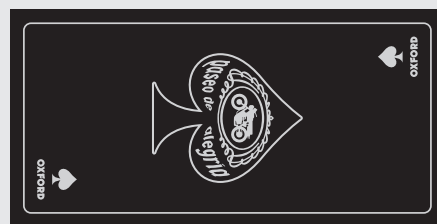

Sport



NEW WORKSHOP MATS L

FEATURES

- Sewn edge to hold back spills
- Hard wearing polyester
- 5mm deep pile carpet
- Size: 200 x 100cm
- Fluid resistant TPR backing
- Track compliant (meets FIM requirements)

CODE	DESCRIPTION
OX910	Pitlane Red
OX911	Pitlane Yama Blue
OX912	Pitlane Suzi Blue
OX913	Pitlane Green
OX914	Pitlane Orange
OX915	Flame
OX916	Adventure
OX917	Scrambler
OX918	Cafe
OX919	Sport
OX692	Motorcycle mat -Racing



Sport

Racing



Zero-G

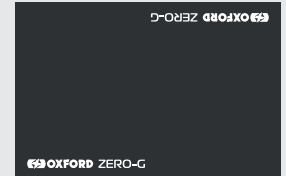

Pitlane Red

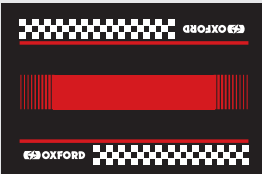

Pitlane Yama Blue



Pitlane Suzi Blue



Pitlane Green



Pitlane Orange

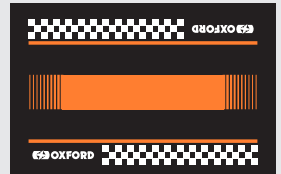

Scrambler



Flame



Adventure



Cafe



There is a God



Tinkerer



My Rules



Welcome



Good Vibes



Ride



NEW DOOR MATS

Indoor entrance mat

FEATURES

- Made from a strong and durable 100% Polyester 3mm deep pile carpet.
- Non-slip Latex Foam backing
- For internal use only
- Dimensions: 90cm x 60cm

CODE	DESCRIPTION	CODE	DESCRIPTION
OX930	Pitlane Red	OX939	Sport
OX931	Pitlane Yama Blue	OX940	Zero-G
OX932	Pitlane Suzi Blue	OX941	My Rules
OX933	Pitlane Green	OX942	Racing
OX934	Pitlane Orange	OX943	Good Vibes
OX935	Flame	OX945	Welcome
OX936	Adventure	OX947	There is a God
OX937	Scrambler	OX950	Tinkerer
OX938	Cafe	OX952	Ride

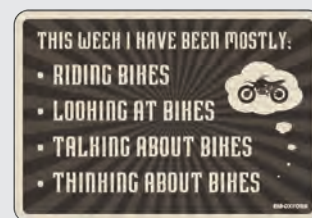
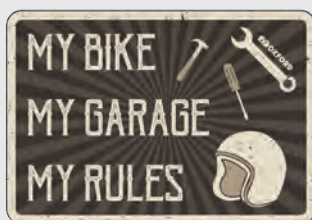

NEW GARAGE SIGN

FEATURES

- Made from high quality coated metal tin plate with rolled edges
- 4 x 3.2mm pre-drilled holes for attachment
- Dimensions: 30 x 20cm x 0.25mm thick
- Weight: 124g



CODE	DESCRIPTION
OX378	Garage Metal Sign - MY RULES
OX379	Garage Metal Sign - GOOD VIBES
OX380	Garage Metal Sign - PARKING
OX381	Garage Metal Sign - WELCOME
OX382	Garage Metal Sign - RIDE FREE
OX383	Garage Metal Sign - THERE IS A GOD
OX384	Garage Metal Sign - BEWARE
OX385	Garage Metal Sign - THIS WEEK
OX386	Garage Metal Sign - TINKERER
OX387	Garage Metal Sign - TEMPLE
OX388	Garage Metal Sign - RIDE
OX389	Garage Metal Sign - EXCITING
PCMSRACK	POS Garage Sign Rack

TOOLSTASH

Compact tool roll

FEATURES

- 34 elasticated tool locations
- 600D PCV Backed polyester
- 3 layer padded construction
- Reinforced window pocket for visible extras
- Steel eyelets to facilitate hanging in a workshop
- Hook-and-loop fastening compression straps with bar-tack reinforcements

Dimensions

- 150 x 285mm (closed)
- 575 x 285mm (open)

TOOLS NOT INCLUDED



CODE	DESCRIPTION
------	-------------

OL259	Toolstash
-------	-----------



TOOL KIT PRO

27 piece underseat tool kit

FEATURES

- Ergonomically designed, soft gel handles
- Chrome vanadium steel
- Compact storage case

CODE

OX770



TOOL KIT

28 piece underseat tool kit

FEATURES

- Ergonomically designed, soft gel handles
- High quality carbon steel construction
- Compact storage case

CODE

OX771

SOCKET SET 1

11 piece socket & ratchet set

FEATURES

- Made from chrome vanadium steel
- Reversible
- 72 teeth, smooth action
- Sizes: 10-19, 22mm
- Comfortable gel handle

CODE

OX159

SPINDLE KEY

Front wheel removal tool

FEATURES

- CNC machined high quality steel
- 4 sizes in 1: 17mm, 19mm, 22mm, 24mm

CODE

OX775

SOLO

Brake bleeding kit

FEATURES

- Universal fitment with securing clips included
- Clear tubing to see air bubbles leaving the master cylinder
- One-way alloy valve prevents air being drawn into the system



CODE

OX776



CHAIN TOOL

Chain breaking & riveting tool

Designed to break chains, press fit connecting link plates, and rivet pin heads

CONTENTS

- Chain tool
- Anvil
- Flare pin
- 6mm, 8mm and stepped side plates
- Alignment bolt
- Pin holder
- Replacement pin
- Guide nut

CODE	DESCRIPTION
OX777	Chain tool
OF292P	Spare Pins (Pair)



CABLE REPAIR KIT

Underseat cable repair kit

FEATURES

- Used for the temporary fix of broken cables
- Supplied in a handy aluminium storage tin
- Includes: Solderless nipples, nipples, 2x Bowden cables

CODE
OX774



CABLE LUBE TOOL

Lubrication tool

FEATURES

- Dual screw for a tighter seal
- Easy to use
- Made of anodised aluminium

CODE
OX773



WORKSHOP

HEX WRENCH

Long handle hex key

FEATURES

- Resin grip
- Ball end

CODE	SIZE
------	------

TL123	4mm
TL124	5mm
TL125	6mm
TL126	8mm

HEX KEY SET

9 keys 1.5-10mm

CODE

TL120

REFLECTORS

Self-adhesive reflectors

FEATURES

- Fully MOT compliant
- East to fit
- Pack of 2

CODE	DESCRIPTION
------	-------------

OX803	Circle
OX804	Rectangle

SCREEN SCREWS

Anodised screen screws

FEATURES

- 5 colours available
- Includes: 8 x M5 mushroom head bolts, 8x Nylon washers, 8x 9mm expansion bushes, M3 hex key

CODE	DESCRIPTION
------	-------------

OX563	Silver
OX564	Black
OX565	Blue
OX566	Gold
OX567	Red





OIL CHANGE ACCESSORIES

OIL CATCHER

- 6 litre capacity
- Wide pan catches any oil splashes
- Pouring spout for clean disposal
- Durable plastic construction

SILICONE FUNNEL

- Compact design folds down when not required; perfect for garage use
- Flexible material ideal for narrow spaces

OIL FILTER WRENCH

- Durable steel construction
- Size range: 65-105mm
- Soft grip
- Designed for the installation and removal of filters and filter cartridges

CODE	DESCRIPTION
OX704	Oil Filter Wrench
OX618	Oil Catcher
OX619	Silicone Funnel



BUNG 2 & 4

For 2 or 4 stroke motorcycles

Stop water going up your exhaust pipe when cleaning your bike by using one of these Oxford Bungs.

FEATURES

- Robust soft rubber compound
- Easy-to-grab handle makes removal simple



CODE	DESCRIPTION
OX768	2 Stroke
OX769	4 Stroke

MAGNETO

Magnetic workshop tray

A magnetic workshop tray. It is such a handy tool to help prevent the loss of steel parts during repairs.

FEATURES

- Stainless steel
- 15cm diameter tray
- 8cm diameter base encapsulated in rubber



CODE
OX772



FOGHORN

12v black motorcycle horn

FEATURES

- Waterproof and corrosion proof construction
- Universal mounting bracket, will fit most motorcycles and scooters

CODE
OX805



12V HORN

Essential 105dB horn

FEATURES

- Suitable for 12v motorcycles and scooters
- Universal mounting bracket to fit most motorcycles and scooters
- Epoxy powder coated for long term corrosion resistance

CODE	DESCRIPTION
OX779	Black
OX780	Chrome



WASH BUCKET

20L bucket with grit guard

FEATURES

- Grit guard sits at the bottom of the bucket, trapping dirt to prevent it from being reintroduced to the sponge or brush whilst cleaning
- 20L capacity
- Heavy duty folding handle
- Made from tough, durable plastic

CODE
OX257



BUCKET BAG

Collapsible 12L bucket bag

FEATURES

- Made from tough 400D PVC
- High-frequency welded waterproof seams
- Reinforced contents viewing window
- Secure rope handles and rim reinforcement

CODE
OX260



NEW NOODLE GLOVE

Double action cleaning glove

FEATURES

- Perforated mesh, removes dead bugs
- Noodle sponge gently cleans
- Machine-washable
- Use wet or dry to clean outside and inside car

CODE
OX261



NOODLE SPONGE

2-in-1 microfibre wash pad

FEATURES

- Perforated mesh, removes dead bugs
- Noodle sponge gently cleans
- Machine-washable
- Elasticated strap makes it easy to grip whilst cleaning

CODE
OX252

NEW EXPANDING SPONGE

Extra large cleaning sponge

FEATURES

- Lifts dirt, dust and grime
- Hand-washable
- 215mm x 110mm
- 50mm thick

CODE
OX249



NEW POLISH APPLICATOR

Pair of soft foam applicator pads

FEATURES

- Ideal for applying waxes, polishes and detailing liquids
- Hand-washable
- Re-usable
- 130mm diameter
- 20mm thick

CODE
OX262



SUPER DRYING TOWEL

Soft absorbent microfibre towel

FEATURES

- Scratch, lint & streak free
- Cleans and dries simultaneously
- Machine-washable
- 90x55cm

CODE
OX255



NEW WAFFLE DRYING TOWEL

Soft absorbent waffle towel

FEATURES

- Absorbs 3x the water of a traditional terry towel, with fast, spot free results
- Machine-washable
- 80x40cm

CODE
OX239



ULTRA SOFT MICROFIBRE TOWELS

Pack of 6 multi-purpose microfiber towels

FEATURES

- Ideal for cleaning, polishing and waxing
- Washable
- 35x35cm

CODE
OX259



MICROFIBRE TOWELS

Pack of 6 multi-purpose microfiber towels

FEATURES

- Ideal for cleaning, polishing, detailing or wiping up water, oil and chemicals
- Washable
- 40x30cm

CODE
OX253



NEW DRIP PADS

Multi-pack of absorbent drip pads

FEATURES

- 4x 2mm plastic backed pads, 4x 5mm max absorption pads
- Each pad absorbs >0.5L
- Prevents oil stains by absorbing oil
- Repels water
- 39 x 48cm

CODE
OX100



BAG OF RAGS

Microfibre bag of rags

FEATURES

- Ideal for cleaning, polishing, detailing or wiping up water, oil and chemicals
- Assortment of sizes and colours
- Washable
- Streak-free results

CODE	DESCRIPTION
OX250	500g
OX251	1Kg



CHAIN BRUSH

Multi-faced chain brush

FEATURES

- Long bristles for heavily soiled chains
- Can prevent premature wear and tear to chain, with regular use
- Suitable for most chain sizes

CODE
OX731



BIG SOFTIE

Large soft cleaning brush

FEATURES

- Rubberised impact zones
- Tough, impact resistant handle
- Angled for easy use
- Large brush head
- Durable nylon bristle

CODE
OX732



DOUBLE STUBBLE

Double density cleaning brush

FEATURES

- Double density construction
- Angled for easy use
- Tough, impact resistant handle
- Durable nylon bristles

CODE
OX733



PRONG BRUSH

Forked cleaning brush

FEATURES

- Rubberised safety tip
- Tough, impact resistant handle
- Flexible
- Durable nylon bristles

CODE
OX734



TYRE SCRUB

Tyre cleaning brush

FEATURES

- Tough, impact resistant handle
- Tyre shaped brush
- Rubberised impact zones
- Durable nylon bristles

CODE
OX737



WHEELY CLEAN

Large wheel cleaning brush

FEATURES

- Long reach brush head
- Rubberised safety tip
- Tough, impact resistant handle
- Durable nylon bristles

CODE
OX735



CLAW BRUSH

Drivetrain cleaner

FEATURES

- Claw for digging out grime
- Brush for cleaning sprocket teeth
- Brush for cleaning chains
- Durable nylon bristles

CODE
OX736



NEW DETAILING BRUSHES

5-piece detailing brush set

FEATURES

- Hardwearing plastic handles
- Scratchless bristles
- Anti-swirl protection

CODE
OX723



CABLE TIES

Pack of 100 black cable ties

CODE	DESCRIPTION
BR303	2.5 x 100mm
BR304	3.6 x 200mm
BR309	3.6 x 300mm



TRIPLE BRUSH SET

Pack of 3 cleaning brushes

INCLUDES

- Wheely clean
- Claw
- Prong brush

CODE
OX738



BRUSH & SCRUB

Pack of 4 cleaning brushes

INCLUDES

- Double stubble
- Wheely clean
- Big softie
- Prong brush

CODE
OX739

NEW TUBE TAX DISC HOLDER

Aluminium tax disc holder

FEATURES

- Waterproof seal
- Universal fit
- Hex key included
- Size: 110 x 26mm



CODE	DESCRIPTION
OX830	Tube Tax Disc Holder



NEW HEXAGONAL TAX DISC HOLDER

Aluminium tax disc holder

FEATURES

- Waterproof seal
- Universal fit
- Hex key included
- Size: 90 x 125mm



CODE	DESCRIPTION
OX831	Hex Tax Disc Holder



DOCUMENT HOLDER

Plastic insurance slip holder

FEATURES

- Tough, durable Polyethylene material
- Rain-resistant, self-sealing construction
- Anti-tamper design
- 87 x 74mm

CODE
OF758



OXFORD



BEST IN SHOW

RANGE OVERVIEW

A carefully formulated range of specialist cleaning and maintenance products to make your pride and joy 'best in show'

NEW

Visit our new dedicated Mint micro website:
www.oxfordmint.co.uk

BIKE CLEANING



Bike Wash 1L
OC100



Bike Wash 5L
OC101FB



Chain Cleaner
OC200



Bike Degreaser
OC201



Brake Cleaner
OC202

BIKE LUBES



Dry Weather Lube
OC205



Wet Weather Lube
OC206



All Weather Lube
OC207



Chain Clean & Lube Kit
OC500

BIKE KITS

BIKE DETAILING



Silicone Detailer
OC203



General Protectant
OC204

KIT CARE



Helmet Sanitiser
OC300 - 200ml
OC305 - 100ml



Anti-Fog Spray
OC301 - 250ml
OC304 - 50ml



Helmet Cleaner
OC302 - 250ml
OC306 - 50ml



Helmet Care Kit
OC303



Wax Reproofer
OC400 - 250ml



Visormate
OC307 - 50ml

BIKE WASH

An ALL-PURPOSE CLEANER specially formulated to remove dirt and grime quickly, resulting in a BRIGHT AND SPARKLING FINISH to your bike.

FEATURES

- Mint Bike Wash is a high performance formulation
- Foaming trigger enables easy and gentle removal of dirt and grime
- Safe on paintwork, metal surfaces, plastics, rubber and carbon fibre
- Features a clean, mint scent

GREAT FOR... EVERYWHERE!

- Paintwork
- Engine casings
- Metal work
- Wheels
- Forks
- Etc.



1 LITRE CODE:OC100

5 LITRE CODE:OC101FB

QUICK AND EASY TO USE!

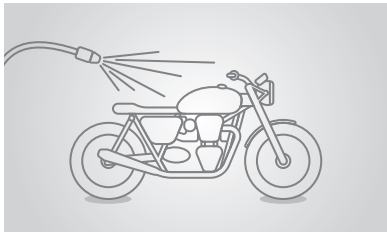

1. Rinse the bike thoroughly before applying Mint Bike Wash.

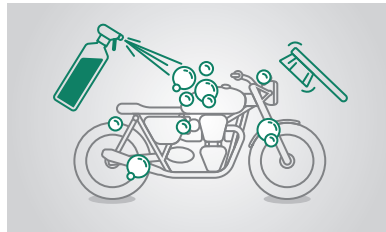

2. Spray on Mint Bike Wash and leave for several minutes. Use an Oxford cleaning brush to ensure an even coverage. Agitate areas with heavy dirt deposits.

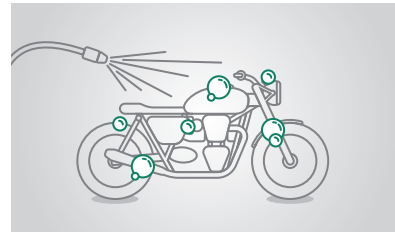

3. Rinse thoroughly with clean water.



Bottle can be attached to a pressure washer or used with the trigger provided

CHAIN CLEANER

A POWERFUL FORMULATION which is extremely effective at dissolving and washing away contaminated chain lube and the combination of oil and dirt which has dried on over time. An emulsifying formula allows the product to be washed off after use.

FEATURES

- Easy to use. High power delivery ensures dirt and grime is removed quickly
- Safe to use on chains, swing arms, O, X and Z ring chains
- Regular cleaning of your chain will extend the life of your chain and maintain performance



GREAT FOR...

- Chains
- Sprockets
- O, X, Z rings

500ml

CODE:OC200

BIKE DEGREASER

A ROBUST FORMULATION which is extremely effective at dissolving and washing away grease and oily residues that have dried and set over time. SLOW-EVAPORATING solvents remain on the surface for longer, in order to dissolve more dirt; more effective if allowed to soak for a few minutes before being wiped off. An emulsifying formula allows the product to be washed off after use.

FEATURES

- Mint Degreaser removes built up oil and grease
- Allow moving parts to move freely
- Deep penetrating action



GREAT FOR...

- Engine blocks
- Rear pegs
- Stands

500ml

CODE:OC201

BRAKE CLEANER

SPECIALLY FORMULATED to remove any build-up of brake dust and dirt and leave a decontaminated surface for the perfect functioning of your brakes. Acetone-free and safe on rubber components.

FEATURES

- Mint Brake Cleaner is easy to use, high power delivery removes brake dust and brake fluid
- Rapid working formula leaves the brakes clean in minutes



GREAT FOR...

- Disc brakes
- Brake calipers
- Clutches

500ml

CODE:OC202

DRY WEATHER LUBE

SPECIALLY FORMULATED with selected oils, PTFE and fewer solvents to generate a high film-forming capability; this works to produce a stronger and more robust film, reducing 'fling' and improving chain protection in dry and dusty conditions. PTFE content fills the gaps between moving parts to reduce dirt ingress.

FEATURES

- Ideal for dry and dusty conditions
- Special formulation with PTFE helps prevent dirt and grime adherence



GREAT FOR...

- Chains
- Sprockets
- O, X, Z rings

500ml

CODE:OC205

WET WEATHER LUBE

SPECIALLY FORMULATED with a high anti-corrosion content and a film forming wax with a resin binder to improve durability and performance in very wet conditions. PTFE content fills the gaps between moving parts to reduce dirt ingress.

FEATURES

- Mint Wet Weather Lube has been developed to deal with the most inclement weather conditions
- Long lasting protection with PTFE



GREAT FOR...

- Chains
- Sprockets
- O, X, Z rings

500ml

CODE:OC206

ALL WEATHER LUBE

SPECIALLY FORMULATED viscous lubricant with corrosion inhibiting additives to create a tenacious film, which extends the maintenance intervals and increases the life of your chain. PTFE content fills the gaps between moving parts to reduce dirt ingress.

FEATURES

- Mint All Weather Lube is ideal for extended journeys
- Special formulation with anti-fling properties
- Long lasting protection and lubrication with PTFE



GREAT FOR...

- Chains
- Sprockets
- O, X, Z rings

500ml

CODE:OC207

SILICONE DETAILER

AN INNOVATIVE BLEND of oils which hides minor blemishes on surfaces, reducing the appearance of small cracks and scratches. Quick and easy to apply, it also provides a protective layer to surfaces and reduces the possibility of finger prints and other smudges appearing.

FEATURES

- Easy application
- Reduced friction on moving parts
- Helps reduce cleaning
- Stays looking clean for longer



GREAT FOR...

- Paintwork
- Petrol tanks
- Carbon fibre
- Fairings

500ml

CODE:OC203

GENERAL PROTECTANT

A HIGHLY EFFECTIVE general purpose protectant with strong film forming properties, which create a protective coating to prevent moisture ingress and damage on all types of components. Particularly suitable for overwintering and long term storage to help maintain condition of all components, including moving parts, metal fasteners, rubber seals and electronics.

FEATURES

- Mint Protectant is ideal for repelling moisture
- Enhances protection against dirt and grime
- Light wax coating ensures longevity of protection



GREAT FOR...

- Springs
- Fork stanchions
- Rust prone areas

500ml

CODE:OC204



HELMET CARE KIT

Everything you need to maintain the cleanliness and functionality of your helmet and visor. Comes with a handy EVA foam pouch for convenient motorcycle storage.

- Helmet Sanitiser (100ml)
- Anti-Fog Spray (50ml)
- Helmet Cleaner (50ml)
- Microfibre cloth
- EVA foam pouch



GREAT FOR...

- On-the-go general helmet care

CODE:OC303

HELMET SANITISER

Formulated specifically to clean and safely sanitise the interior fabric on helmets. It can also be used on boots, gloves and other safety items that are worn for extended periods. REFRESHES AND SANITISES in one operation.

- Easily and gently sanitises helmet liners
- Safe on all materials
- Features a special foaming applicator
- Contains mild, tested biocide
- Can also be used on gloves, shoes and boots



GREAT FOR...

- Internal helmet linings
- Gloves, shoes and boots

100ml

CODE:OC305

200ml

CODE:OC300

ANTI-FOG SPRAY

A specially developed, easy-to-use anti-fog fluid for visors and goggle lenses. This formulation provides a natural STREAK-FREE lustre in seconds, leaving a pleasant, light fragrance with no sticky residues.

- Effective and suitable for most surfaces
- No residual dust or streaks
- Cleans and polishes in one application
- Non-sticky



GREAT FOR...

- Visors
- All shell types

50ml

CODE:OC304

250ml

CODE:OC301

HELMET CLEANER

A unique formulation specifically designed to clean helmets and visors without streaking. When applied with a microfibre cloth this product leaves no residue and a SMEAR-FREE surface even in direct sunlight.

- Removes road dirt, dead insects and greasy residue
- Unique formulation
- Easy application
- Quick drying
- Low hazard formulation, safe on all surfaces



GREAT FOR...

- Ensuring clear vision
- Debugging after a summer ride

50ml

CODE:OC306

250ml

CODE:OC302

WAX REPROOFER

Stain free, silicone free proofer for wax cotton garments. Quickly and conveniently restore your wax jacket's waterproofing.

- Suitable for all colours of waxed cotton
- Easy to use
- Quick top-up application
- PFC free



GREAT FOR...

- Revitalising waxed cotton garments

250ml

CODE:OC400

VISORMATE

A unique formulation specifically designed to clean visors without streaking.

- Pump action bottle
- Cleaning fluid included
- Integrated sponge
- Integrated visor wipe
- Refillable Bottle



GREAT FOR...

- Maintaining a clear view through your visor.

50ml

CODE:OC307

CHAIN CLEAN & LUBE KIT

CONTAINS

- Chain cleaner (OC200)
- All weather lube (OC207)
- Chain brush (OX731)

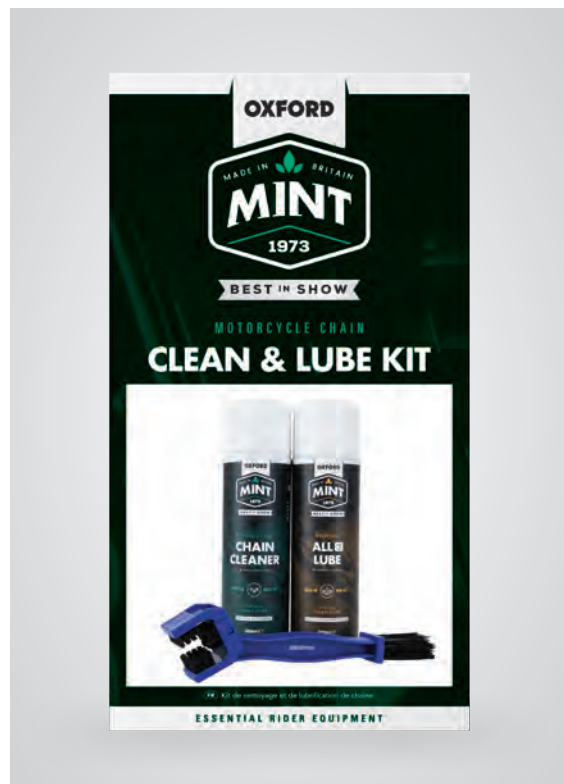

CODE:OC500

TYRE CARE



TYRE CARE

TYRE WARMERS

3 level tyre warmers

Designed to get the best out of your track and racing days. Pre-heating prolongs the life of the tyres and, more importantly improves tyre performance.

FEATURES

- Automatic thermostat controls temperature to 60, 80 or 95°C when fitted to the tyres
- Sold as a pair
- Front fits tyres from: 120/70 x 17"
- Rear fits tyres up to: 200/55 x 17"
- LCD temperature display
- LED heat indicator
- Rolls up neatly into carry bag provided
- Clear label pocket to display tyre information
- Made from heat resistant material, reinforced with nylon, with hook-and-loop fasteners for quick and easy attachment and removal
- Power consumption: Front 400W, Rear 600W, per pair 1000W
- CE approved



CODE	DESCRIPTION
OX673	Tyre Warmers LCD 3
OX673EU	Tyre Warmers LCD 3 EU Plug
OX673G	Tyre Warmer Temp Gauge

TYRE GAUGE PRO

Analogue pressure gauge

FEATURES

- Ø 2"/5cm Steel case and ring
- Tough acrylic window
- Holds the peak pressure reading
- Pressure bleeding button
- Long 14"/36cm flexible hose with 90° angled head
- Gauge unit protected in a rubber casing
- 0-60psi/0-4 bar for motorcycles, cars, caravans, etc



CODE	DESCRIPTION
OX750	Tyre Gauge Pro



DIGI GAUGE

Advanced digital pressure gauge

FEATURES

- Rotating dual valve system: Schrader and Presta
- Reads a choice of pressure scales: PSI/BAR/kPa/KG/CM2
- Pressure range: 0.20 to 11.03 BAR. 3 to 160 PSI. 20 to 1103 kPa
- Back-lit digital display for easy reading
- Pressure release valve
- Anti-shock case
- Flashlight included

CODE
OX751



AIR GAUGE

Digital pressure gauge

FEATURES

- Digital display
- Reads a choice of pressure scales: PSI/BAR/kPa/KG/CM2
- Fits Schrader valves
- Pressure range: 0 to 6.9 BAR. 0 to 100 PSI. 0 to 690 Kpa
- Automatic shut-off
- Includes 4 x valve caps

CODE
OX752



AIRTRACK GAUGE

Steel floor pump with gauge

FEATURES

- Twin head fits Presta & Schrader valves
- Includes adaptors for ball and inflatables
- 160PSI Max Pressure
- 630mm length
- Long air pipe for greater reach

CODE
PU850



AIRTRACK

Steel floor pump

FEATURES

- Twin head fits Presta & Schrader valves
- Includes adaptors for ball and inflatables
- Long air pipe for greater reach
- 160PSI Max Pressure

CODE
PU851

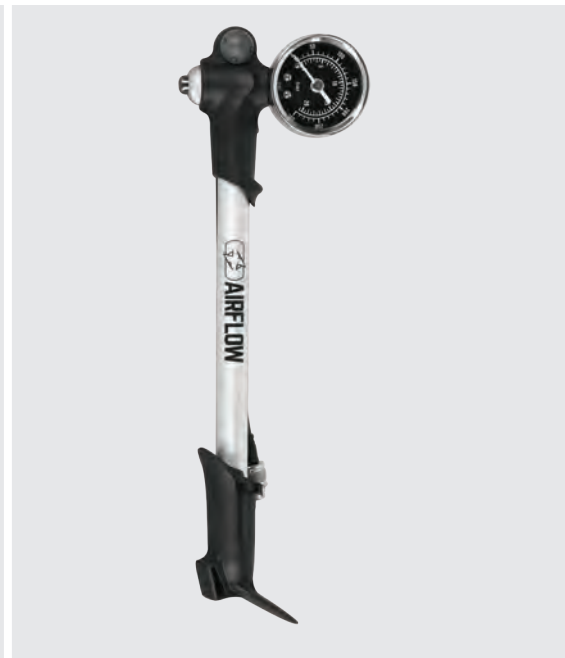

AIRFLOW SHOCK

Shock pump with gauge

FEATURES

- Analogue pressure gauge
- 300 PSI Max Pressure
- Precision alloy barrel
- Pressure release button
- 6" pivoting hose

CODE
PU770

TYRE CARE



VALVE TOOL

Flexible valve access tool

FEATURES

- Allows access in confined spaces for a more accurate pressure reading
- Compact - fits in to your pocket or toolkit
- Fits Schrader valves
- 167mm flexible hose

CODE
OX753

VALVE 90

90° valve adaptor

FEATURES

- Schrader connection with 'O' Ring seal
- Stainless steel corrosion resistant valve cap
- For inflation only - do not leave attached
- Chrome plated brass

CODE
OX754

WHEEL STRIPES

Motorcycle rim tape

FEATURES

- Easy to fit in minutes using 3M™ rim applicator
- 7mm wide to fit 17" rims
- 6m length is sufficient for both sides of two 19" motorcycle wheel rims
- Applicator included

CODE	COLOUR
OF614	Orange
OF615	Yellow
OF616	Green
OF617	Red
OF618	Blue
OF619	White



WHEEL STRIPES

Motorcycle rim tape

FEATURES

- Unique pre-curved 4 part design
- Easy to apply - no applicator required
- 7mm wide

CODE	COLOUR
OF515	Yellow
OF516	Green

VALVE CAPS

FEATURES

- Internal 'o'ring for a perfect air seal

CODE DESCRIPTION

OX760	Lucky Dice
OX767	8 Ball
OX766	Skull
OX761	Gripper - Silver
OX762	Gripper - Red
OX763	Gripper - Blue
OX765	Gripper - Black



CO2 TYRE REPAIR 1

Emergency tyre repair & CO² inflation kit

FEATURES

- 5 x tyre sealant sticks
- 1 x insertion tool
- 3 x 16g CO² canisters
- 1 x valve
- 1 x knife
- 1 x reamer tool
- 1 x CO² canister cover
- 1 x rubber solution
- 1 x carry pouch

CODE
OX720

CO2 TYRE REPAIR 2

Rapid tyre inflation system

FEATURES

- Compatible with schrader & presta valves
- 16g threaded cartridges (3/8 inch - 24 UNF)
- 1 x CO² cartridge cover
- 1 x regulating valve

CODE
OX721



CO2 TOP-UPS

Pack of 4 replacement CO² canisters

FEATURES

- 4 x 16g CO² canisters
- 1 x CO² canister cover

CODE
OX722



CO2 TOP-UPS

Pack of 30 replacement CO² canisters

FEATURES

- Replacement CO² canisters in POS packaging
- 16g threaded cartridges (3/8" UNF)
- MPN: OX162

CODE
OX162

PAINT PROTECTION





GLOWZ

Luminous motorcycle tank protector

FEATURES

- Glow in the dark
- Universally shaped to fit most bikes, but can be cut down to size
- Weather resistant
- Super thin

Size: 208(L) x 150(W)mm

CODE	COLOUR
OX641	



ARACHNID SPINE

Motorcycle tank protector

FEATURES

- Raised gel protects paintwork
- Universal design
- Can be cut to fit the smallest tank
- Weather resistant

Size: 220(L)
x 158(W)mm

CODE	COLOUR
OX646	Black
OX647	Carbon



ORIGINAL SPINE

Gel tank protector

FEATURES

- Raised gel protects paintwork
- Universal design
- Can be cut to fit the smallest tank
- Weather resistant

Size: 210(L)
x 150(W)mm

CODE	COLOUR
OX651	Black
OX652	Carbon



SPINE

Super-thin tank pad

FEATURES

- Universally shaped to fit most bikes, but can be cut down to size
- Mini protectors included
- Weather resistant

Size: 210(L)
x 150(W)mm

CODE	COLOUR
OX648	Clear
OX649	Black
OX644	Carbon
OX650	Emb carbon



SHEER ARROW

Universal super-thin vinyl tank pad

FEATURES

- Universal shape to fit most bikes, but can be cut down in size
- Weather resistant

Size: 210(L)
x 150(W)mm

CODE	COLOUR
OX541	Red
OX542	Silver

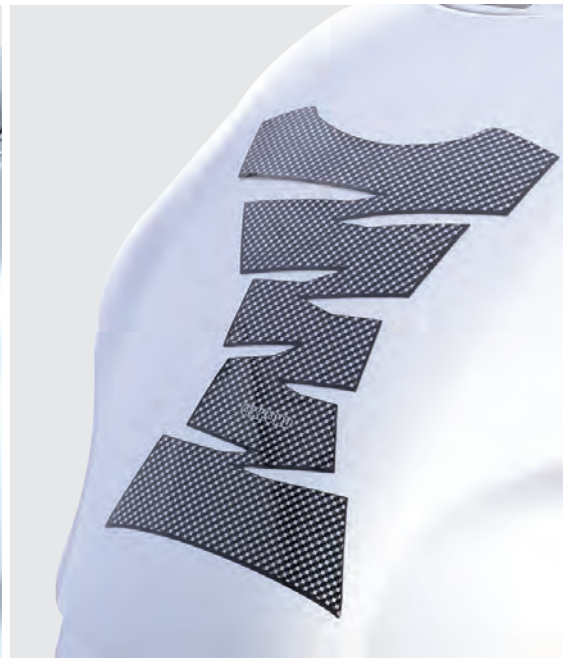

JAGGED

Universal super thin tank pad

FEATURES

- Universal shape to fit most bikes, but can be cut down in size
- Weather resistant

Size: 207(L)
x 145(W)mm

CODE	COLOUR
OX639	Carbon
OX640	Black
OX545	Silver

PAINT PROTECTION



NEW GRIPPER ADV

Universal silicone tank and knee pads for adventure bikes

TANK PAD

- 3mm silicone construction
- Oil, chemical and temperature resistant
- Top quality 3M™ adhesive

KNEE PADS

- 3mm silicone construction
- Oil, chemical and temperature resistant
- Top quality 3M™ adhesive
- Ideal for textile clothing

CODE	DESCRIPTION
OX801	Tank pad
OX802	Knee pads

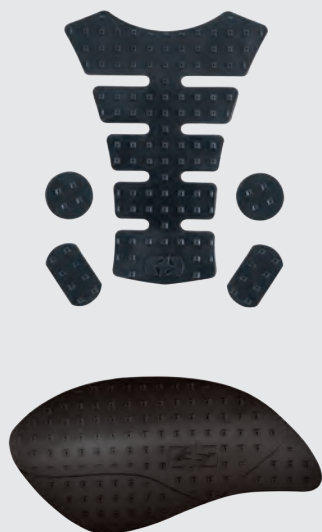

TANK GRIPS

Pack of 2 universal silicone knee pads

TANK PAD

- Hollow square teeth create high level of mechanical grip
- Oil, chemical and temperature resistant
- Top quality 3M™ adhesive
- Mini protectors included
- Can be cut to fit any size of tank

KNEE PADS

- Hollow square teeth create high level of mechanical grip
- Oil, chemical and temperature resistant
- Top quality 3M™ adhesive
- Pre moulded cut lines (can be cut to size)
- Ideal for use with leather race suits

CODE	DESCRIPTION
OX670	Knee pads
OX833	Tank pad



GRIPPER

Universal silicone tank and knee pads

TANK PAD

- 2.5mm silicone construction
- Oil, chemical and temperature resistant
- Top quality 3M™ adhesive
- Can be cut to fit any size tank
- Mini protectors included
- Ideal for textile clothing

KNEE PADS

- 2.5mm silicone construction
- Oil, chemical and temperature resistant
- Top quality 3M™ adhesive
- Pre moulded cut lines (can be cut to size)
- Ideal for use with textile clothing

CODE	DESCRIPTION
OX655	Tank pad
OX615	Knee pads



TRANSFORMER

Modular tank and knee pads

TANK PAD

- Universal modular design
- Unique traction grip texture
- Top quality 3M™ adhesive
- Fits a variety of tank shapes and sizes

KNEE PADS

- Universal modular design
- Unique traction grip texture
- Top quality 3M™ adhesive
- Fits a variety of tank shapes and sizes

CODE	DESCRIPTION
OX798	Tank pads
OX799	Knee pads

PAINT PROTECTION



PAINTSAVER

Cut-your-own transparent protectors

FEATURES

- Cutter guide included
- Place in areas that are prone to knocks and scratches
- Sheet Size: 425mm x 665mm



CODE
OX657



TRANSFORMER SHEET

Cut-your-own textured protectors

FEATURES

- Cut to fit any area
- Weather resistant
- Unique traction grip texture
- 3M top quality adhesive
- Sheet Size: 375mm x 300mm



CODE
OX793



TANK SAVER

Gel tank knee pads

FEATURES

- Clear adhesive allows decals & paint to show through
- Self adhesive
- Universal size

CODE
OX645



BLANKET

Multi-purpose anti-slip mat

FEATURES

- Cut to fit any size
- Soft construction prevents abrasion
- Ideal for protecting paintwork when using luggage
- Minimises object movement
- Size: 600mm x 900mm

CODE
OX653

A close-up, low-key photograph of a motorcycle's front lighting assembly. The main focus is a large, round, clear lens headlight with three distinct LED elements visible inside. To the left of the main headlight, a horizontal LED strip is illuminated with a warm orange glow. Below the main headlight, a small, brown leather saddlebag is attached to the frame. The background is dark, highlighting the metallic and plastic components of the bike's front end. A blue rectangular box with white text is overlaid on the right side of the image.

LIGHTING



SEQUENTIAL INDICATORS

The ultimate trick upgrade. The indicator dynamically sweeps across from the inside to the outside of the indicator strip, when activated. A universal fit makes these a must-have for any bike



E-Marked



Universal fit



Waterproof design



2 x resistors included

SEQUENTIAL INDICATORS

NightSlider Front

2-IN-1 SEQUENTIAL INDICATORS, DAYTIME LIGHTS



- Contains 14 LEDs housed in a tough, matt black ABS body
- 7 LEDs for daytime lights
- 7 LEDs for indicators
- Voltage 12V Power 2W
- M8 bolt - thread pitch 1.25
- Sold as a pair

ACTUAL SIZE

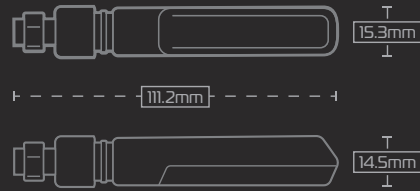

CODE
EL359

NightSlider Rear

3-IN-1 SEQUENTIAL INDICATORS, BRAKE & TAIL LIGHTS



- Contains 14 LEDs housed in a tough, matt black ABS body
- 7 LEDs for stop & rear position
- 7 LEDs for rear indicators
- Voltage 12V Power 2W
- M8 bolt - thread pitch 1.25
- Sold as a pair

ACTUAL SIZE

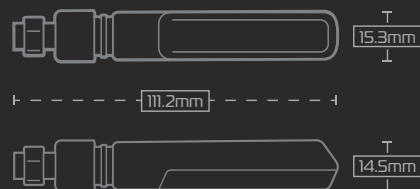

CODE
EL360

SEQUENTIAL INDICATORS

NightGlider

SEQUENTIAL LED INDICATORS



- Contains 7 LEDs behind a smoked lens, housed in a tough, matt black case
- For use on front or rear
- Voltage 12V Power 2W
- M8 bolt - thread pitch 1.25
- Sold as a pair

ACTUAL SIZE

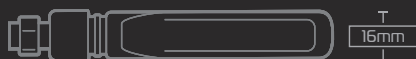

CODE
EL361

NightStrider

SEQUENTIAL LED INDICATORS

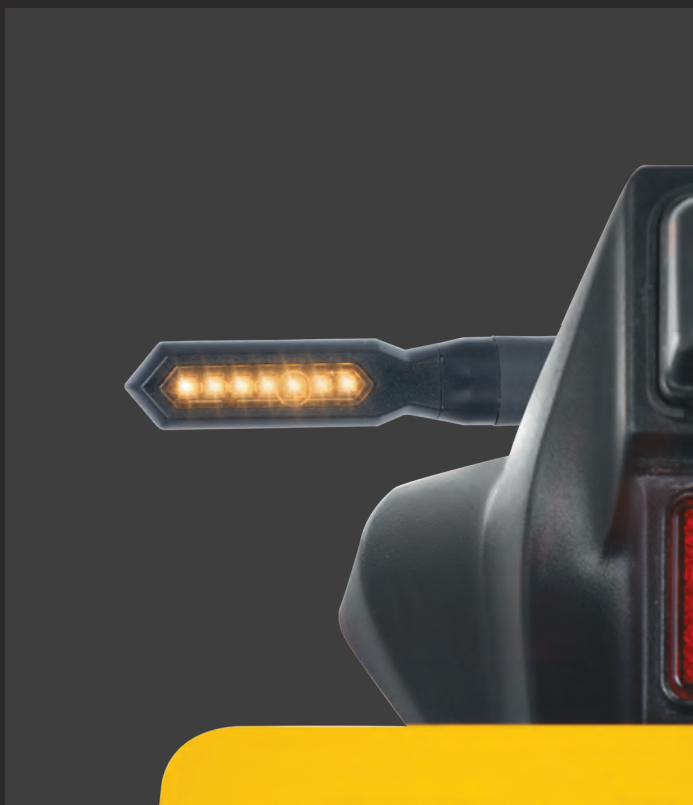

- Contains 7 LEDs behind a smoked lens, housed in a tough, matt black case
- For use on front or rear
- Voltage 12V Power 2.4W
- M8 bolt - thread pitch 1.25
- Sold as a pair

ACTUAL SIZE

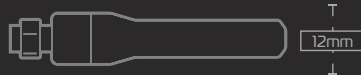

CODE
EL362

SEQUENTIAL INDICATORS

NightRider SEQUENTIAL LED INDICATORS

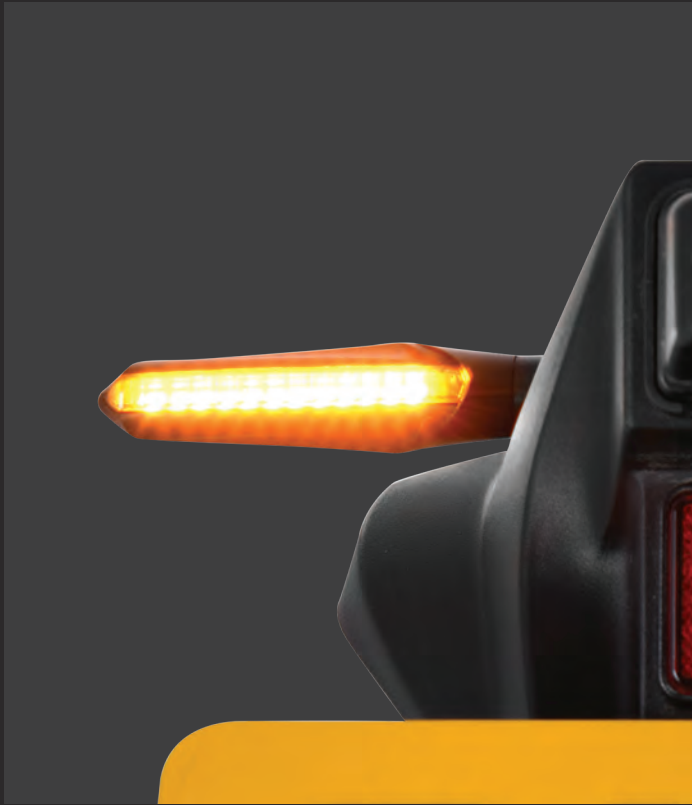

- Sleek design with short stem & 12 LED bulb (extra bright)
- Premium quality matt black case
- For use on front or rear
- Voltage 12V Power 1.3W
- M8 bolt - thread pitch 1.25
- Sold as a pair

ACTUAL SIZE

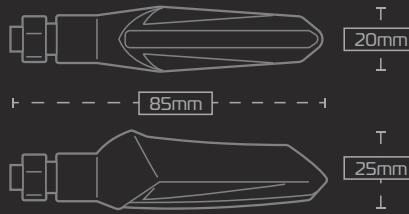

CODE
OX621



ADVANCED LED INDICATORS



E-Marked

x2

Sold as pair



Weatherproof design



2 x resistors included

Nano



- Unique Oxford design
- Super bright LED
- Sealed for life

Dimensions

49(L) x 22(W) x 20.4(H)mm

CODE

EL329

Nano All Black



- Unique Oxford design
- Super bright LED
- Sealed for life

Dimensions

49(L) x 22(W) x 20.4(H)mm

CODE

EL328

Apollo



- High intensity Light Emitting Diodes
- Ultra-reliable
- Vibration tested
- Sealed for life

Dimensions

98(L) x 25(W) x 13(H)mm

CODE

OF360

Neptune



- High intensity Light Emitting Diodes
- Ultra-reliable
- Vibration tested
- Sealed for life

Dimensions

98(L) x 30(W) x 37(H)mm

CODE

OF365

Mercury



- Unique Oxford design
- Super bright LEDs
- Sealed for life

Dimensions

89(L) x 23(W) x 27(H)mm

CODE
EL331

Columbia



- High intensity Light Emitting Diodes
- 'Honeycomb' lens technology
- Ultra-reliable
- Vibration tested

Dimensions

103(L) x 25(W) x 15(H)mm

CODE
EL330

Jupiter



- Optimise your visibility
- Much longer life-span than conventional bulb-lit indicators
- Ultra reliable
- Vibration tested
- Sealed for life

Dimensions

109.2(L) x 27(W) x 17(H)mm

CODE
EL332

Saturn



- 'Honeycomb' lens technology
- Longer life-span
- Ultra reliable
- Vibration tested
- Sealed for life

Dimensions

72(L) x 33.3(W) x 21(H)mm

CODE
EL333

Atom



- Universal fit
- Mini indicators with smoked lens
- 3 LED's with matt black finish case
- Voltage 12v, Power 2.4W
- M8 Bolt - Thread pitch 1.25

Dimensions

58(L) x 13(W) x 13(H)mm

CODE
EL350



PREMIUM LED INDICATORS

Signal 1



- 18 LEDs with black Zinc alloy case
- Weatherproof design
- E-marked
- 2x indicators and 2x resistors included

Dimensions

76(L) x 23(W) x 19(H)mm

CODE
EL301

Signal 3



- 15 LEDs with matt black finish case
- Highly waterproof
- E-marked
- 2x indicators and 2x resistors included

Dimensions

103(L) x 25(W) x 15(H)mm



15 LEDs

CODE
EL322

Signal 4



- 15 LEDs with matt black finish case
- Highly waterproof
- E-marked
- 2x indicators and 2x resistors included

Dimensions

74(L) x 29(W) x 18(H) mm



15 LEDs

CODE
EL323

Signal 7



- 12 LEDs with matt black finish case
- Short stem
- Highly waterproof
- E-marked
- 2x indicators and 2x resistors included

Dimensions

76(L) x 27(W) x 27(H) mm



12 LEDs

CODE
EL324

Signal 14



- 12 LEDs with matt black finish case
- Short stem
- Highly waterproof
- E-marked
- 2x indicators and 2x resistors included

Dimensions

69(L) x 28(W) x 42(H) mm



12 LEDs

CODE
EL325

Signal 15



- 12 LEDs with matt black finish case
- Long stem
- Highly waterproof
- E-marked
- 2x indicators and 2x resistors included

Dimensions

87(L) x 28(W) x 42(H) mm



12 LEDs

CODE
EL326

STANDARD LED INDICATORS



E-Marked

x2

Sold as pair

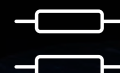

2 x resistors included

Rectangular



- 9 super bright LEDs
- Sealed-for-life for greater longevity
- Voltage 12V Power 1W
- M8 bolt - thread pitch 1.25mm

Dimensions

74 or 95(L) x 38(W) x 33(H)mm

CODE	DESCRIPTION
EL335	Rectangular Short
EL336	Rectangular Long

Round



- Universal fitment using bullet connections
- Uses 12V x 23W amber bulb
- Includes wiring and connectors

Dimensions

85(L) x 30(W) x 60(H)mm

CODE
OF552

Arrow



- 15 super bright LEDs
- Compact and stylish design
- Voltage 12V Power 2W
- M8 bolt - thread pitch 1.25mm

Dimensions

69 or 86(L) x 27(W) x 40(H)mm

CODE	DESCRIPTION
EL337	Arrow Short
EL339	Arrow Long

Arrow Carbon



- 15 super bright LEDs
- Compact and stylish design
- Voltage 12V Power 2W
- M8 bolt - thread pitch 1.25mm

Dimensions

69(L) x 27(W) x 40(H)mm

CODE	DESCRIPTION
OF550	Arrow Carbon

Indicator Spacers



HONDA OX816 Shaped outer x2 Flat inner x2	HONDA / SUZUKI OX818 Shaped outer x2 Flat inner x2	SUZUKI TYPE 1 OX819 Shaped outer x2 Flat inner x2	SUZUKI TYPE 2 OX820 Shaped inner/outer x4
KAWASAKI OX817 Shaped inner/outer x4	YAMAHA TYPE 1 OX821 Shaped inner/outer x4	YAMAHA TYPE 2 OX822 Shaped inner/outer x4	YAMAHA TYPE 3 OX823 Shaped outer x2 Flat inner x2

Covers holes left by standard sized indicators in bodywork



SCAN FOR COMPATIBILITY CHART OR VISIT
WWW.OXFORDPRODUCTS.COM/INSTRUCTIONS

CODE	DESCRIPTION
OX816	Honda
OX817	Kawasaki
OX818	Honda/Suzuki
OX819	Suzuki type 1
OX820	Suzuki type 2
OX821	Yamaha type 1
OX822	Yamaha type 2
OX823	Yamaha type 3

Tail Light - 3-in-1 LED number plate, brake & tail light



- Universal fit
- Waterproof design
- 23 super bright LEDs
- Sealed-for-life for greater longevity
- Rubber mounted to absorb vibrations

Dimensions
120(L) x 32(W) x 35(H)mm

CODE
EL343

Halo Light - LED number plate



- Universal fit
- Waterproof design
- 3 super bright LEDs
- Specification: 12V, 0.45W

Dimensions
24(H) x 50(W) x 15(D)mm

CODE
EL344

Indicator Leads



Each bike manufacturer uses different connectors for their indicators. This means that when fitting universal aftermarket indicators you need to cut the original connectors off and replace them with bullet fittings. Not any more! Simply connect the IndyLeads between the original connector and the universal indicator. Simple. 2 pack for front OR rear.

CODE	DESCRIPTION
OX885	Kawasaki Type 1
OX886	Kawasaki Type 2
OX887	Kawasaki Type 3
OX888	Yamaha
OX889	Yamaha MT-07
OX890	Yamaha 2 wire connector
OX891	Yamaha 3 wire connector w/ day light function
OX892	Honda 2 wire connector
OX893	Honda 3 wire connector
OX894	KTM
OX895	Suzuki
OX896	Aprilia
OX897	BMW
OX898	Ducati
OX899	Triumph

Halo Bolts

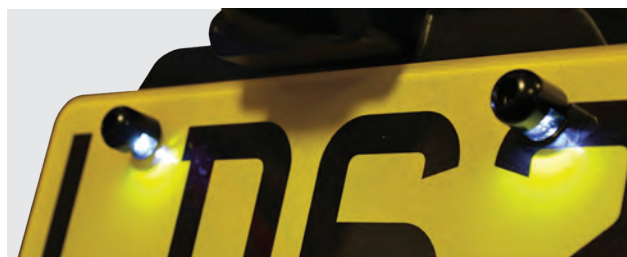

- Super bright LEDs
- Low power consumption
- 12mmø x 14mm(L) bolt size
- Easy to install

CODE
EL345

Resistors



If your LED indicators flash too fast then fit the Oxford load balancing resistors.

- Stabilises LED indicator flash rates
- Simple to fit bullet connectors
- Works with low power bulb indicators
- Two models available (18 Watt and 9 Watt)

CODE	DESCRIPTION
EL320	18 WATT / 10 OHM CERAMIC RESISTORS
EL321	9 WATT / 21.5 OHM CERAMIC RESISTORS

Replacement Bulbs



21 Watt replacement bulbs available in clear and orange.

CODE	DESCRIPTION
BULB21W	MINI INDICATOR 21W CLEAR
BULB21WO	MINI INDICATOR 21W ORANGE



HOTGRIPS™

THE ORIGINAL. THE BEST.

TOASTY TOASTY

"If you are tired of numb hands on cold mornings, this is what you need; the solution to all your cold weather problems."



SIMPLY THE BEST

"I already have a set of these on my big bike so no-brainer for my small bike. Fast heating with a good variety of temperature settings. Easy to install and well made. The best heated grips available in my opinion."



EXCELLENT PRODUCT

"Second pair of Oxford grips I have bought - now fitted to two of my bikes. They are hotter than the factory fitted grips on my BMW with a wider range of settings. Wouldn't have a bike without them now."





WHAT'S IN THE BOX?

1 x Heat Controller

2 x Hotgrips™

1 x Mounting Bracket

Wiring Loom

Cable Ties, Grip Glue & Fitting instructions



/OxfordproductsLtd



SIMPLE INSTALLATION

Head to our YouTube to check out our Hotgrips™ installation video



HOTGRIPS™ EVO

A WORLD FIRST

The EVO HotGrips™ are a technological leap forward and will dramatically increase the enjoyment of winter riding.

These completely all-new HotGrips™ now feature thermistor technology in each grip, which allows them to heat up faster and then automatically regulates the exact surface temperature in accordance with the temperature that you set on the heat controller.

So no matter what the ambient temperature might be, your grips will always be at the temperature that you want, never too hot or too cold. The ATV model has thermistor control integrated into both the grip and the thumbwarmer.

Re-designed rubberised internals are easier to fit and more secure than conventional heated grips.



THERMISTOR CONTROLLED HEAT SETTINGS

NEW & UNIQUE thermistor technology auto-regulates temperature

Built into each HotGrip™ (and thumbwarmer for the ATV model) is a temperature measuring thermistor that provides feedback to the heat controller.

Set the desired temperature and the controller automatically monitors and maintains the precise temperature.

Heats up fast at full power until the temperature is achieved.

Precise Temperature Control

Choose from 5 precise temperature settings ranging from 35°C to 45°C. LED lights will indicate the temperature setting.

Intelligent Heat Setting Memory

This innovative function stores the previous heat setting and defaults to this at power-up, saving time when in regular use. Note: This function is only available if the heat controller is connected to the ignition.

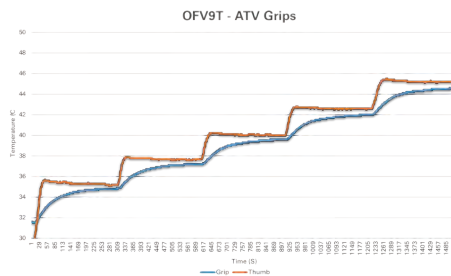

Weatherproof Design

The intelligent heat controller uses a sealed-for-life welded case construction for long-term durability and weatherproofing. New weatherproof power connectors further protect your HotGrips™ against the elements.

Waterproof screw connectors - IP67 Rated



Battery Saving Mode

The Battery Saving Mode protects against flat batteries. If you forget to turn the switch off, it will do it for you!

Auto shut off



Simple Installation

HotGrips™ are designed as a replacement for the handlebar grips already fitted to the motorcycle/ATV. They will fit onto 7/8" (22mm) Ø handlebars. Through-moulded rubber gives a strong and reassuring glue bond to the handlebar.

Ergonomically engineered surface structures to optimise riding performance.



NEW motorcycle controller unit



NEW ATV controller unit



HOTGRIPS™ EVO ADVENTURE

Thicker rubber in areas of maximum wear; square tread pattern for vibration absorption; 5² block sided tread patterns for high levels of grip and feel; diamond tread pattern where maximum grip is required and a waffled area for finger-grip control. The grip length is 132mm but can be trimmed to 122mm if required and has open ends so that bar end weights can be fitted.

CODE
EL420

HOTGRIPS™ EVO TOURING

Ideal for comfortable long distance cruising. Thicker rubber in areas of maximum wear; rhombus tread pattern for vibration absorption; 5² block sided tread patterns for high levels of grip and feel; diamond tread pattern where maximum grip is required. The grip length is 120mm but can be trimmed to 110mm if required and has open ends so that bar end weights can be fitted.

CODE
EL421



WITH THUMBWARMER

HOTGRIPS™ EVO SPORTS

Soft, ultra-grippy diamond tread is inspired by race grips for comfort and feedback. The grip length is 123mm but can be trimmed to 114mm if required and has open ends so that bar end weights can be fitted.

CODE
EL422

HOTGRIPS™ EVO ATV

Dual channel heat controller gives independent control for the grips and thumb-warmer. The grips have ergonomically engineered surface structures to optimize riding performance. Thicker rubber in areas of maximum wear; rhombus tread patterns for high levels of grip and feel; diamond tread pattern where maximum grip is required and a waffled area for finger-grip control. The grip length is 130mm but can be trimmed to 120mm and has open ends so that bar end weights can be fitted. Glue-less clamp fitting makes them easy to fit.

CODE
EL423

HOTGRIPS™ PREMIUM

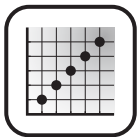

5 heat settings



Weatherproof design



Draws under 4A



Simple installation



Battery saving mode

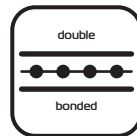

Sealed for life



The grips have ergonomically engineered surface structures to optimise riding performance. Thicker rubber in areas of maximum wear.

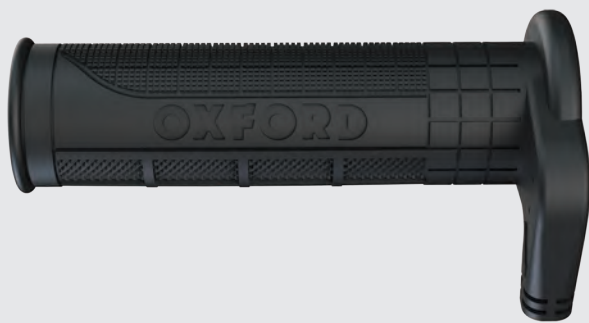

Clutch mounting bracket & fitting kit

HOTGRIPS™ PREMIUM ADVENTURE

Square tread pattern for vibration absorption; 5² block siped tread patterns for high levels of grip and feel; diamond tread pattern where maximum grip is required and a waffled area for finger-grip control.

- 132/122mm length
- Fits 22mmØ handlebars

HOTGRIPS™ PREMIUM CRUISER

These grips are specifically designed for motorcycles for diameter 1"(25mm)Ø handlebars. The grip has removable chrome end caps so that bar end weights can be fitted.

- 138/119mm length
- Fits 25.4mmØ handlebars

CODE	DESCRIPTION
OF690	Premium adventure hotgrips™

CODE	DESCRIPTION
EL800	Premium cruiser hotgrips™



HOTGRIPS™ PREMIUM TOURING

Rhombus tread pattern for vibration absorption. Special block grip patterns with sipes for high levels of grip and diamond tread pattern where maximum grip is required.

- 120/110mm length
- Fits 22mmø handlebars

CODE	DESCRIPTION
OF691	Premium touring hotgrips™

HOTGRIPS™ PREMIUM SPORTS

Soft, ultra-grippy diamond tread is inspired by race grips for comfort and feedback.

- 123/114mm length
- Fits 22mmø handlebars

CODE	DESCRIPTION
OF692	Premium sports hotgrips™



HOTGRIPS™ PREMIUM RETRO

Ultra-grippy diamond tread pattern for comfort, which also absorbs vibration and is also styled to complement retro motorcycles.

- 120/110mm length
- Fits 22mmø handlebars

CODE	DESCRIPTION
EL693	Premium retro hotgrips™

HOTGRIPS™ PREMIUM ATV

Thick rubber with a five square block tread pattern, gives medium wear resistance and maximum vibration absorption.

CODE	DESCRIPTION
OF770	Premium atv hotgrips™

HANDLEBAR ACCESSORIES

ESSENTIAL HOTGRIPS™ COMMUTER

These Hotgrips™, although universal, have been designed to be compatible with motorcycles with smaller batteries and less powerful charging systems.

FEATURES

- Weather resistant heat controller, can reach up to 45°C
- Grip design fits 22mmØ handlebars and can be cut down in length if required (52mmWx30mmDx24mmH)
- 1-piece moulded construction ensures unrivalled performance and reliability
- Draws under 4A
- Zero back drain current
- Bracket and fitting included

CODE	DESCRIPTION
OF771	Hotgrips™ commuter



- 1 Moulded wiring arrangement is both durable & discreet
- 2 Soft, ultra-grippy rubber provides comfort & feedback
- 3 2 way rainproof switch with High/Low function

ESSENTIAL HOTGRIPS™ CRUISER

These Hotgrips™ have been designed specifically for motorcycles with 1" handlebars, typically cruisers.

FEATURES

- Ergonomically engineered grip surface structures.
- 1-piece moulded construction ensures unrivalled performance and reliability
- Draws under 4A
- Rainproof switch

CODE	DESCRIPTION
OF697	Cruiser hotgrips™



- 1 Moulded wiring arrangement is both durable & discreet
- 2 Chrome end cap can be used; or cut it off and use your own Bar End (additional dark chrome end caps included)
- 3 Ergonomic temperature control comes complete with mounting bracket
- 4 Soft, ultra-grippy rubber provides comfort and feedback

ESSENTIAL HOTGRIPS™ SCOOTER

These Hotgrips™ have been designed specifically for scooters and bikes with smaller batteries and less powerful charging systems. Ideal for commuting and city riding.

FEATURES

- Ergonomically engineered grip surface structures.
- 1-piece moulded construction ensures unrivalled performance and reliability
- Grip design fits the vast majority of bikes, but can be cut down in size if required
- Draws under 4A
- Rainproof switch
- 2 bar end caps included

CODE	DESCRIPTION
OF772	Hotgrips™ scooter



- 1 Moulded wiring arrangement is both durable & discreet
- 2 Durable rubber tread absorbs vibrations while providing good levels of grip
- 3 Weather-resistant, panel-dash fit switch with 2 heat settings

ESSENTIAL HOTGRIPS™ ATV

FEATURES

- Ergonomically engineered grip surface structures
- 1-piece moulded construction ensures unrivalled performance and reliability
- Grip design fits the vast majority of bikes, but can be cut down in size if required

CODE	DESCRIPTION
OF769	Hotgrips™ ATV

NEW HOTGRIPS WRAP

Advanced heated overgrips

FEATURES

- Quick to attach or remove via hook-and-loop fitting
- 2 heat settings
- Waterproof connectors
- Draws under 3Amps
- Fits up to 32mm ø grip



CODE	DESCRIPTION
EL694	HotGrips Wrap

CLEAN GRIPS

Handlebar grip protectors

FEATURES

- Hook and loop fitting
- Protects your grip from spills
- Fits most handlebars

CODE	DESCRIPTION
OX606	Clean Grips



- 1 Moulded wiring arrangement is both durable & discreet
- 2 2 way switch with High/Low function
- 3 Soft, ultra-grippy rubber provides comfort & feedback



HANDLEBAR ACCESSORIES

AVANZA GRIPS ADVANCED

Alloy composite grips

FEATURES

- Constructed from high quality, 6063 grade anodised alloy and non-slip rubber
- Weatherproof and UV resistant
- Durable TPE construction
- Open ended grip which is compatible with all bar ends
- Easy-to-fit to handlebars
- Suitable for 22.2 mm diameter handlebars
- Grip length 134mm
- 34mm diameter grip

CODE	DESCRIPTION
------	-------------

OX610	Silver
OX611	Black

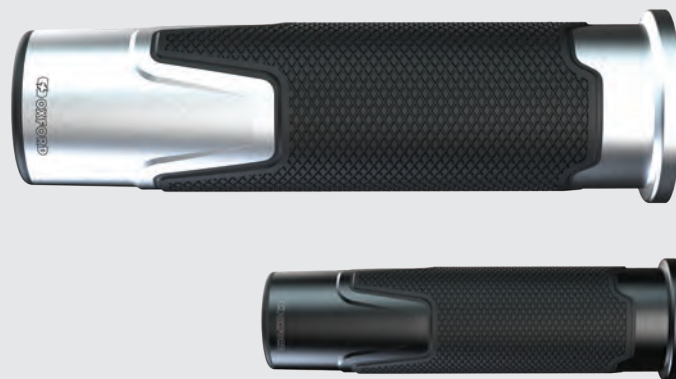

TECNICO GRIPS ADVANCED

Alloy composite grips

FEATURES

- Constructed from high quality, 6063 grade anodised alloy and non-slip rubber
- Weatherproof and UV resistant
- Durable TPE construction
- Open ended grip which is compatible with all bar ends
- Easy-to-fit to handlebars
- Suitable for 22.2 mm diameter handlebars
- Grip length 134mm
- 34mm diameter grip

CODE	DESCRIPTION
------	-------------

OX612	Silver
OX613	Black



ADVENTURE GRIP

Medium compound replacement grips

FEATURES

- 2x bar end plugs included
- Suitable for 22 mm diameter handlebars
- Grip length 119mm
- 29mm diameter grip

CODE	DESCRIPTION
------	-------------

OX602	Adventure grips
-------	-----------------



SPORTS GRIPS

Medium compound replacement grips

FEATURES

- 2x bar end plugs included
- Suitable for 22 mm diameter handlebars
- Grip length 119mm
- 29mm diameter grip

CODE	DESCRIPTION
------	-------------

OX603	Sports grips
-------	--------------



TOURING GRIPS

Medium compound replacement grips

FEATURES

- 2x bar end plugs included
- Suitable for 22 mm diameter handlebars
- Grip length 119mm
- 29mm diameter grip

CODE	DESCRIPTION
OX604	Touring Grips

SUPERGRIPS

Replacement grips

FEATURES

- 2x bar end plugs included
- Suitable for 22 mm diameter handlebars
- Grip length 125mm
- 29mm diameter grip

CODE	DESCRIPTION
OX600	Supergrips 125mm

RETRO GRIPS

Medium compound replacement grips

FEATURES

- 2x bar end plugs included
- Suitable for 22 mm diameter handlebars
- Grip length 119mm
- 29mm diameter grip

CODE	DESCRIPTION
OX620	Retro grips

FAT GRIPS

Medium compound replacement grips

FEATURES

- 2x bar end plugs included
- Suitable for 22 mm diameter handlebars
- Grip length 119mm - 116mm trimmable
- 33mm diameter grip

CODE	DESCRIPTION
OX605	Fatgrips



HANDLEBAR ACCESSORIES

BAR ENDS 1

Medium weight aluminium bar end

FEATURES

- Suitable for 22 mm diameter handlebars
- CNC aluminium
- Includes: 2x bar ends, 13 & 18mm expansion bushes, 5mm hex key



CODE	DESCRIPTION
OX589	Silver
OX590	Red
OX591	Blue
OX592	Gold
OX593	Black



BAR ENDS 2

Light weight aluminium bar end

FEATURES

- Suitable for 22 mm diameter handlebars
- CNC aluminium
- Includes: 2x bar ends, 13 & 18mm expansion bushes, 5mm hex key



CODE	DESCRIPTION
OX594	Silver
OX595	Red
OX596	Blue
OX597	Gold
OX598	Black



BAR ENDS 3

Heavy weight aluminium bar end

FEATURES

- Suitable for 22 mm diameter handlebars
- CNC aluminium
- Includes: 2x bar ends, 13 & 18mm expansion bushes, 5mm hex key



CODE	DESCRIPTION
OX599	Black



CARB ENDS 1

Aluminium bar end weight

FEATURES

- Suitable for 22 mm diameter handlebars
- CNC aluminium
- Real carbon fibre insert
- Includes: 2x bar ends, 13 & 18mm expansion bushes, 5mm hex key



CODE	DESCRIPTION
OX582	Silver
OX583	Red
OX584	Blue
OX585	Gold
OX586	Black

CARB ENDS 2

Aluminium bar end weight

FEATURES

- Suitable for 22 mm diameter handlebars
- CNC aluminium
- Real carbon fibre insert
- Includes: 2x bar ends, 13 & 18mm expansion bushes, 5mm hex key



CODE	DESCRIPTION
OX587	Silver
OX588	Black

HANDLEBAR ACCESSORIES

PREMIUM LEVER GUARDS

Universal lever guards for brake and clutch

These lever guards protect your handlebar control levers from being engaged accidentally by very close contact with immovable objects (like other bikes on a track day). But they also supply a bit of racer style to your bike too. This concept can equally be applied to road riding, protecting your lever(s) from wing mirror strikes while filtering.

FEATURES

- Universal fitting
- Unique Oxford design
- Lightweight CNC alloy construction
- 12-18mm diameter expansion bushes
- Fits 22mm diameter handlebars
- Packing includes both throttle and clutch lever guards

Tip: You can convert these lever guards to full hand guards by adding the hand guards (OX702) which are available separately.



CODE	DESCRIPTION
------	-------------

OX700	Lever Guards
-------	--------------

OX702	Hand Guard Kit
-------	----------------

PREMIUM HAND GUARDS

Universal hand guards for brake and clutch

Beautifully created handguards to give protection to the rider's hands from stones, weather and general road debris. Adds the finishing touch to a bike that has no guards fitted.

FEATURES

- Universal fitting
- Unique Oxford design
- Lightweight CNC alloy construction
- 12-18mm diameter expansion bushes
- Fits 22mm diameter handlebars
- Packing includes both throttle and clutch lever guards

Tip: You can convert these hand guards to lever guards by adding the hand guards (OX701) which are available separately.



CODE	DESCRIPTION
------	-------------

OX705	Hand Guards
-------	-------------

OX701	Lever Guard Kit
-------	-----------------

RACING LEVER GUARDS

Universal racing lever guards

Lever Guards were originally developed to help avoid the accidental engagement of the front brake lever during close wheel-to-wheel racing. This concept can equally be applied to road riding, protecting your lever(s) from wing mirror strikes while filtering.

FEATURES

- Universal fitting
- Fits all 22mm/ 7/8" handlebars using 12-18 expansion bolts
- Reinforced 'Delrin' acetal 100ST composite
- Suitable for race use
- Easy to install



CODE	DESCRIPTION
OX808	Left Hand - Clutch
OX809	Right Hand - Brake



RACE COMPATIBLE

LEVER GUARDS

Universal lever guards

Lever Guards were originally developed to help avoid the accidental engagement of the front brake lever during close wheel-to-wheel racing. This concept can equally be applied to road riding, protecting your lever(s) from wing mirror strikes while filtering.

FEATURES

- Universal fitting
- Fits all 22mm/ 7/8" handlebars using 12-18 expansion bolts
- Lightweight glass filled nylon construction
- Ideal for track use



CODE	DESCRIPTION
OX797	Left Hand - Clutch
OX796	Right Hand - Brake



HANDLEBAR ACCESSORIES



HORIZON

CNC machined bar end mirrors

FEATURES

- Universal bar end fitment
- Fits 22mm diameter handlebars using 12-18mm expansion bolts
- To be used in conjunction with original-fit mirrors
- Machined from billet aluminium
- Anti-glare convex glass
- Can be fitted above or below handlebars

CODE	DESCRIPTION
OX537	Left
OX538	Right



CAFÉ

CNC machined bar end mirrors

FEATURES

- Universal bar end fitment
- Fits 22mm diameter handlebars using 12-18mm expansion bolts
- To be used in conjunction with original-fit mirrors
- Machined from billet aluminium
- Anti-glare convex glass
- Can be fitted above or below handlebars

CODE	DESCRIPTION
OX534	Universal



STREET

CNC machined bar end mirrors

FEATURES

- Universal bar end fitment
- Fits 22mm diameter handlebars using 12-18mm expansion bolts
- To be used in conjunction with original-fit mirrors
- Machined from billet aluminium
- Anti-glare convex glass
- Can be fitted above or below handlebars

CODE	DESCRIPTION
OX535	Left
OX536	Right



PREMIUM BAR END MIRRORS

Lightweight CNC machined bar end mirrors

FEATURES

- Universal bar end fitment
- Fits 22mm diameter handlebars using 12-18mm expansion bolts
- To be used in conjunction with original-fit mirrors
- 95mm diameter mirror

CODE	DESCRIPTION
OX710	Right
OX711	Left



BAR END MIRRORS

Universal bar end mirrors

FEATURES

- Fits 22mm diameter handlebars using 12-18mm expansion bushes
- To be used in conjunction with original-fit mirrors
- 68mm diameter mirror
- Sold as pair

CODE	DESCRIPTION
OX577	Black
OX578	Silver

DIAMOND PRO

Universal replacement mirror

FEATURES

- Carbon styled insert
- Suitable for most naked bikes
- M10 x 1.25 RH thread
- Mirror adaptors sold separately (pg 137)

CODE
OX154



TRAPEZIUM

Replacement mirror

FEATURES

- Suitable for most naked bikes
- M10 x 1.25 RH thread
- Mirror adaptors sold separately (pg 137)

CODE	DESCRIPTION
OX152	Left
OX153	Right



OVAL

Replacement mirror

FEATURES

- Suitable for most naked bikes
- M10 x 1.25 RH thread
- Mirror adaptors sold separately (pg 137)

CODE	DESCRIPTION
OX572	Left
OX573	Right

HANDLEBAR ACCESSORIES



DIAMOND

Replacement mirror

FEATURES

- Suitable for most naked bikes
- M10 x 1.25 RH thread
- Mirror adaptors sold separately (pg 137)

CODE	DESCRIPTION
OX570	Left
OX571	Right



OBLONG

Replacement mirror

FEATURES

- Suitable for most naked bikes
- M10 x 1.25 RH thread
- Mirror adaptors sold separately (pg 137)

CODE	DESCRIPTION
OX574	Left
OX575	Right



KITE

Replacement mirror

FEATURES

- Suitable for most naked bikes
- M10 x 1.25 RH thread
- Mirror adaptors sold separately (pg 137)

CODE	DESCRIPTION
OX155	Left
OX156	Right



ROUND

Replacement mirror

FEATURES

- Suitable for most naked bikes
- M10 x 1.25 RH thread
- Mirror adaptors sold separately (pg 137)

CODE	DESCRIPTION
OX576	Universal



CHROME

Replacement mirror

FEATURES

- Suitable for most naked bikes
- M10 x 1.25 RH thread
- Mirror adaptors sold separately (pg 137)

CODE	DESCRIPTION
OX569	Left
OX568	Right



NEW BLIND SPOT

Blind spot mirror adaptors

FEATURES

- 360° adjustable
- 49mmø mirror surface
- Simple self adhesive installation
- 2 mirrors included

CODE

OX757



NEW MIRROR EXTENDERS

Aluminium motorcycle mirror extenders

FEATURES

- Extends 40mm out and 51mm high
- Pack of 2
- M10 1.25 RH thread
- Screws included

CODE

OX758



M10 female to MB reverse male thread

LH Mirror

+

M10 female to MB male thread

RH Mirror



M10 female to MB male thread

LH Mirror

+

M10 female to MB male thread

RH Mirror



M10 female to M10 reverse male thread

LH Mirror

+

M10 female to M10 male thread

RH Mirror



MIRROR ADAPTORS

Fittings for universal mirrors

FEATURES

- Enables after market mirrors to be fitted to your motorcycle

CODE	DESCRIPTION
OX580	8mm-10mm Rev ●
OX579	8mm-10mm ●
OX581	10mm-10mm Rev ●

NEW MIRROR PLUGS

CNC Aluminium mirror plugs

FEATURES

- Knurled edge
- 2 clockwise and 1 anti-clockwise plugs included
- Thread pitch: 1.25mm
- Simply remove mirrors and screen in plugs



CODE	DESCRIPTION
OX755	M8
OX756	M10

HANDLEBAR ACCESSORIES

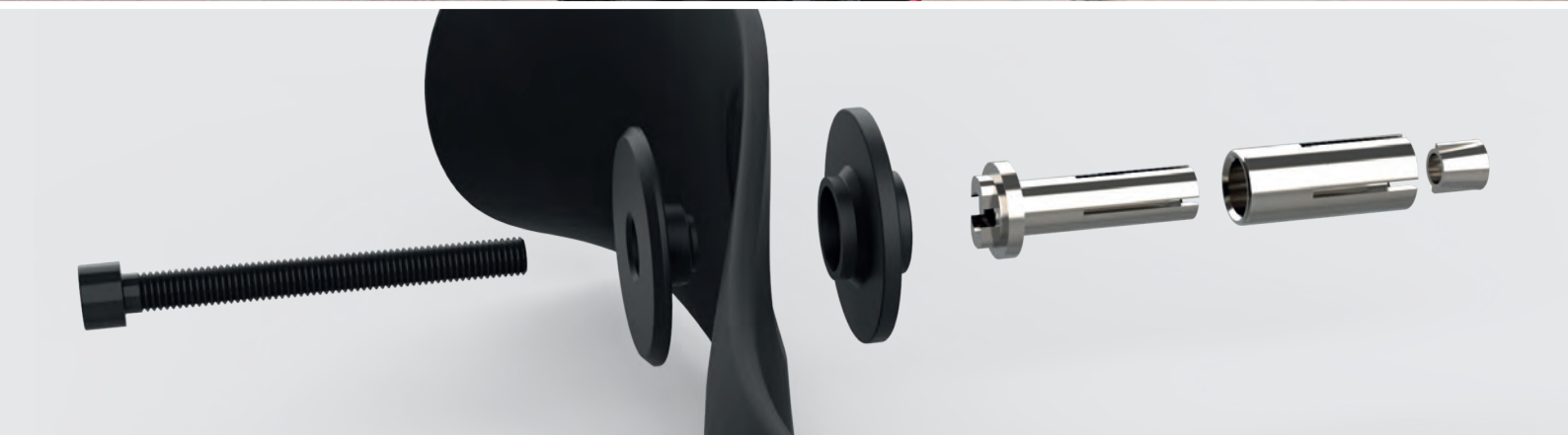

BAR END MUFFS

Muffs with bar end fitting system

These new Oxford Bar End muffs are a game-changer for commuters, re-designed and refined to offer incredible protection against the elements.

Our simple yet ingenious new bar end fixing method allows you to safely access controls without obstructing the full grip use - leaving enough room for winter gloves - and to be used in conjunction with Oxford HotGrips.

FEATURES

- Full weatherproof protection from a tough neoprene outer and bonded seams to keep hands warm and dry.
- Adjustable elasticated cuff for extra wind protection.
- Synthetic fleece upper lining for extra warmth.
- Fits handlebars up to 22mm diameter.
- Reflective detailing for extra visibility.
- Quick and simple installation using either the universal bar end fitment provided OR the existing 6mm or 8mm bolt (if you have an integral handlebar thread).



CODE	DESCRIPTION
OX393	Bar End Muffs
OX396SP	Spare handlebar fitting kit - single muff

HANDLEBAR ACCESSORIES



SUPER MUFFS

Handlebar muffs for motorcycles

Oxford Super Muffs, as used in the 'Long Way Up' expedition, will keep your hands protected from the elements on any journey - short or long.

FEATURES

- Warm, waterproof and windproof for total hand protection
- Special 3D design for efficient and non-snag operation of control levers
- Thermal insulation
- Pre-formed opening for easy access
- 1500 denier polyester fabric for durability
- Reflective piping for increased visibility to other road users
- Universal design that fits the majority of motorcycles

CODE	DESCRIPTION
OX395	Super Muffs

HANDLEBAR ACCESSORIES

DIGICLOCK

Weather resistant digital clock

FEATURES

- Weather resistant digital clock
- Ice alert functionality
- Large glove-friendly buttons
- Monitors ambient temperature
- Back-lit display
- Permanent date display

Size:

46mm(L) x 35mm(W) x 12mm(H)



CODE	DESCRIPTION
------	-------------

OX562	Digiclock
-------	-----------

ANACLOCK

Weather resistant analogue clock

FEATURES

- Extended 4 year battery life
- Tough alloy and stainless steel construction with hardened mineral glass
- 2 fitting options provided
- Swiss Newline luminous clock hands for night-time visibility
- 39mm diameter



CODE	DESCRIPTION
------	-------------

OX559	Black
-------	-------

OX560	Silver
-------	--------

OX561	Titanium
-------	----------

HANDLEBAR ACCESSORIES



INSULEVER

Pair of ergonomic lever sleeves

FEATURES

- Insulated against the cold
- Ergonomic design - finger dents
- 10cm long and stretchy enough to fit over the majority of levers

CODE

OX607



LEVER SLEEVES

Pair of insulating lever sleeves

FEATURES

- 10cm long
- Plain design - no finger dents
- Stretchy enough to fit over the majority of levers

CODE

OX101



CLAMP-ON

Brake lever clamp

FEATURES

- Compresses the brakes during transport or while working on the motorcycle

CODE

OX622



CRUISE

Anti-fatigue throttle assist

FEATURES

- Reduces wrist and hand fatigue
- Assists throttle when cruising
- Universal design in two sizes
- OX608 fits 28-32mm diameter grips;
- OX609 fits 32-36mm diameter grips.

CODE DESCRIPTION

OX608 28 - 32mm

OX609 32 - 36mm

CLIQR

MOUNT YOUR DEVICE, ANYWHERE

VIEW FULL RANGE AT
OXFORDCLIQR.COM

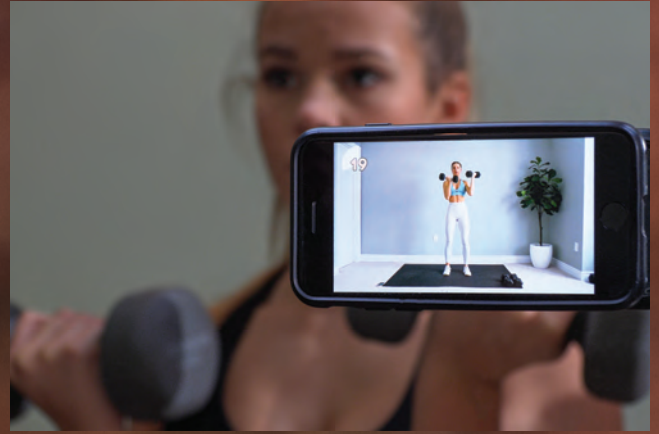

CLIQR



OXFORD'S CLIQR IS THE ULTIMATE WAY TO SECURELY MOUNT YOUR DEVICE

CLIQR uses a dual-locking, fail-safe mechanism to mount almost any device in the most convenient position for you. Simply stick the CLIQR Device Adaptor onto the back of your device and CLIQR it into the mount of your choice, in the orientation that suits you.



Shared Base Mount

The shared base mount is the core of the CLIQR range, providing a secure and quick mounting system, allowing the phone to be in either landscape or portrait orientation. The Dual locking, fail-safe mechanism keeps the phone secure over rough terrain and the simplicity of the mounting system means it can be operated easily with just one hand.



Universal Adaptor With VHB 3M™ Tape

Designed to be attached to the user's phone or phone case, removing the need for a specific bulky phone case with an integrated mounting system.



Mounting option

The CLIQR range provides the best and most versatile mount solutions for any activity.

THE CLIQR HAS BEEN VIGOROUSLY TESTED TO ENSURE YOUR DEVICE IS SECURE, WHEREVER YOU TAKE IT.

DON'T JUST TAKE OUR WORD FOR IT...

CLIQR is extensively tested both in-house and via external bodies to ensure you that your device is safe whilst mounted.

To see the results of our testing, check out www.oxfordcliqr.com to see the following:

3M Technical Data
FEA Simulation
Tensile testing
Vibration testing

Simple to lock and remove with 1 hand



Vertical or horizontal mounting options.



NEW USB MOUNT

The CLIQR USB Handlebar Mount allows you to mount your device beside your controls and charge whilst on the move.

INCLUDES

- 1 x USB handlebar mount
- 2 x Device adaptors
- 1 x Silicone insert (22 - 22.5mm stem/bar)
- 1 x Alcohol wipe

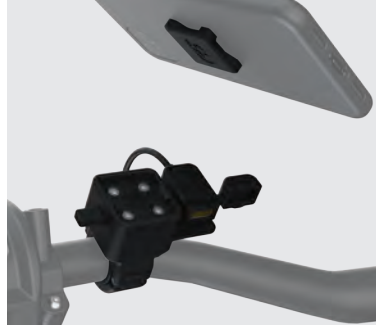

CODE	DESCRIPTION
------	-------------

OX866	USB Mount
-------	-----------

NEW USB CONVERTER MOUNT

The CLIQR USB Converter can seamlessly integrate with any CLIQR mount, allowing you to charge your device on the move.

INCLUDES

- 1 x USB charger
- 1 x USB mount adaptor
- 1 x M3 x 8mm bolt
- 2 x M3 x 22mm bolt



CODE	DESCRIPTION
------	-------------

OX865	USB Converter
-------	---------------

NEW SUCTION CUP MOUNT

The CLIQR Suction Mount can be applied to any non-porous surface. The integrated pivot arm allows for 360 degree rotation for the ideal viewing angle.

INCLUDES

- 1 x Suction mount
- 1 x Pivot arm
- 2 x Device adaptors
- 1 x Alcohol wipe



CODE	DESCRIPTION
------	-------------

OX867	Suction Cup Mount
-------	-------------------



HANDLEBAR ACCESSORIES

CABLE-TIE MOUNT

The CLIQR Cable Tie Mount is a multi-use system that can be fitted in hard-to-reach areas, as well as on multiple diameter tubes offering a low profile mounting system.

INCLUDES

- 1 x Mount
- 2 x Cable ties
- 2 x Device adaptors
- 1 x Silicone spacer
- 1 x 3M™ security tape
- 1 x Alcohol wipe

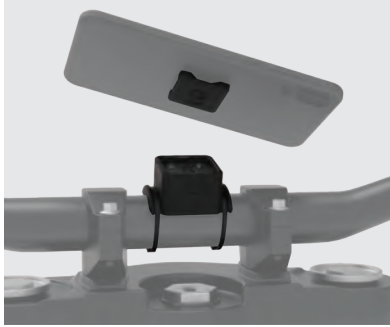

CODE	DESCRIPTION
OX851	Cable-tie Mount CLIQR



MIRROR MOUNT

The CLIQR mirror mount uses a 360° rotating head and 4 TPR rubber shims to fit mirrors stems of 10mm, 12mm, 14mm, 16mm. Ideal for scooters or bikes with limited handlebar space.

INCLUDES

- 1 x Mount
- 2 x Device adaptors
- 1 x 10mm rubber spacer
- 1 x 12mm rubber spacer
- 1 x 14mm rubber spacer
- 1 x 16mm rubber spacer
- 1 x Alcohol wipe



CODE	DESCRIPTION
OX854	Mirror Mount CLIQR



HEADSTOCK MOUNT

The CLIQR headstock mount is designed for use on bikes with clip-on bars.

INCLUDES

- 1 x Mount
- 1 x 12-14.5mm rubber expander
- 1 x 15-17.5mm rubber expander
- 1 x 18-20.5mm rubber expander
- 1 x 21-23.5mm rubber expander
- 1 x 28-31.5mm rubber expander
- 2 x Device adaptors
- 1 x M5 bolt
- 1 x M5 Nyloc nut
- 1 x Washer
- 1 x Alcohol wipe



CODE	DESCRIPTION
OX852	Headstock mount CLIQR



MIRROR STEM MOUNT

Utilises your mirror stems to create a clutter-free mounting solution.

INCLUDES

- 1 x Mount
- 1 x M10 bolt
- 1 x M10 reverse bolt
- 1 x M8 bolt
- 1 x M8 reverse bolt
- 1 x Alcohol wipe

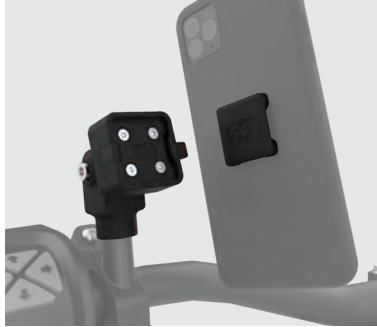

CODE	DESCRIPTION
------	-------------

OX863	Mirror Replacement Mount CLIQR
-------	--------------------------------



HANDLEBAR PIVOT MOUNT

Combining the best-selling 22mm handlebar mount with a cast aluminium twin spar pivoting arm, the CLIQR Handlebar Pivot Mount offers our most convenient fit with 360 degrees of rotation.

INCLUDES

- 1 x Handlebar mount
- 1 x Pivot arm
- 2 x Device adaptors
- 1 x Alcohol wipe



CODE	DESCRIPTION
------	-------------

OX864	Handlebar pivot mount CLIQR
-------	-----------------------------



PIVOT ARM CONVERTER

The CLIQR Universal Pivot Arm can be used with any other CLIQR mount, to offer our most convenient fit with 360 degrees of rotation.

INCLUDES

- 1 x Pivot arm
- 1 x 3M™ VHB adhesive pad
- 1 x Alcohol wipe



CODE	DESCRIPTION
------	-------------

OX862	Pivot ARm Converter CLIQR
-------	---------------------------



HANDLEBAR ACCESSORIES

1" BALL MOUNT

The CLIQR 1" ball mount fits any 1" ball cup to adapt other mounts to the CLIQR system and allow for 360° rotation.

INCLUDES

- 1 x Mount
- 2 x Device adaptors
- 1 x Alcohol wipe

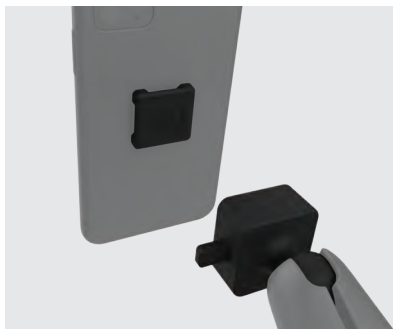

CODE	DESCRIPTION
OX853	1" Ball Mount CLIQR



HANDLEBAR RISER MOUNT

The CLIQR Handlebar Riser Mount replaces your motorcycle riser clamp bolt, allowing you to position your phone in the optimum position without sacrificing space on your bars.

INCLUDES

- 1 x Mount
- 2 x Device adaptors
- 3 x 55mm M6/M8/M10 bolts
- 3 x 20mm M6/ M8/M10 spacers
- 1 x Alcohol wipe

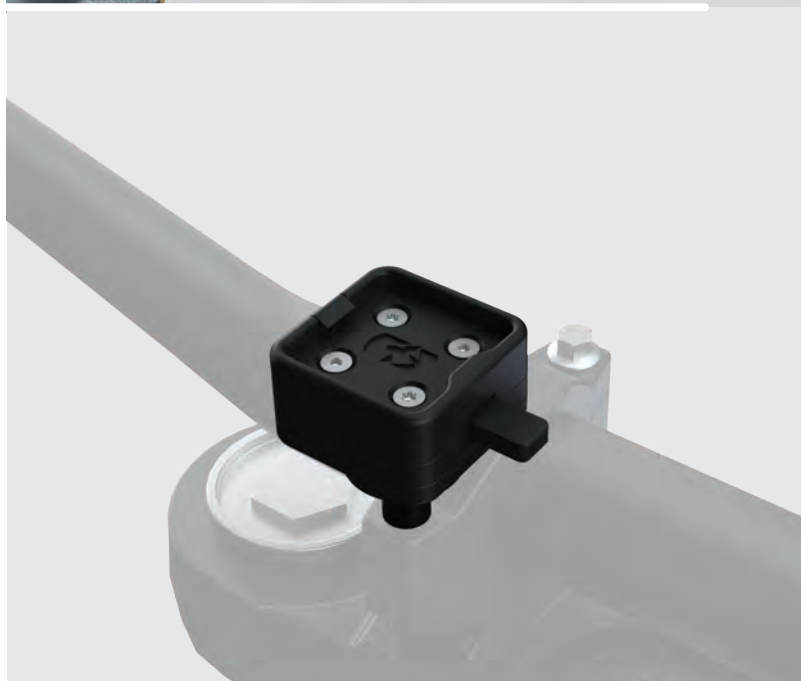

CODE	DESCRIPTION
OX860	Handlebar riser mount CLIQR

ACTION CAMERA MOUNT

The CLIQR action camera mount screws on to your action camera and allows you to mount it on your chosen CLIQR system just like any other device. Perfect for motorcycle, bicycle and other leisure activities.

INCLUDES

- 2 x Action camera mounts



CODE	DESCRIPTION
OX856	Action Camera Mount CLIQR



HANDLEBAR MOUNT

The CLIQR Handlebar Mount is designed specifically for 22mm handlebars, with a hinged clamp and M5 bolt for a secure hold. This mount allows you to position your device beside your controls for convenient viewing at a glance, perfect for navigating on the move.

INCLUDES

- 1 x Mount
- 2 x Device adaptors
- 1 x Silicone insert
- 1 x Alcohol wipe

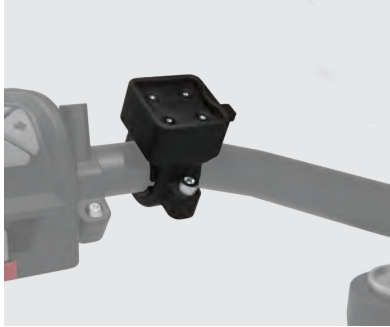

CODE	DESCRIPTION
OX850	Handlebar mount CLIQR



CAR VENT MOUNT

The CLIQR car vent mount uses dual vent mounting clamps to securely hold your device in either landscape or portrait mode.

INCLUDES

- 1 x Mount
- 2 x Device adaptors
- 1 x Alcohol wipe



CODE	DESCRIPTION
OX857	Car Vent Mount CLIQR

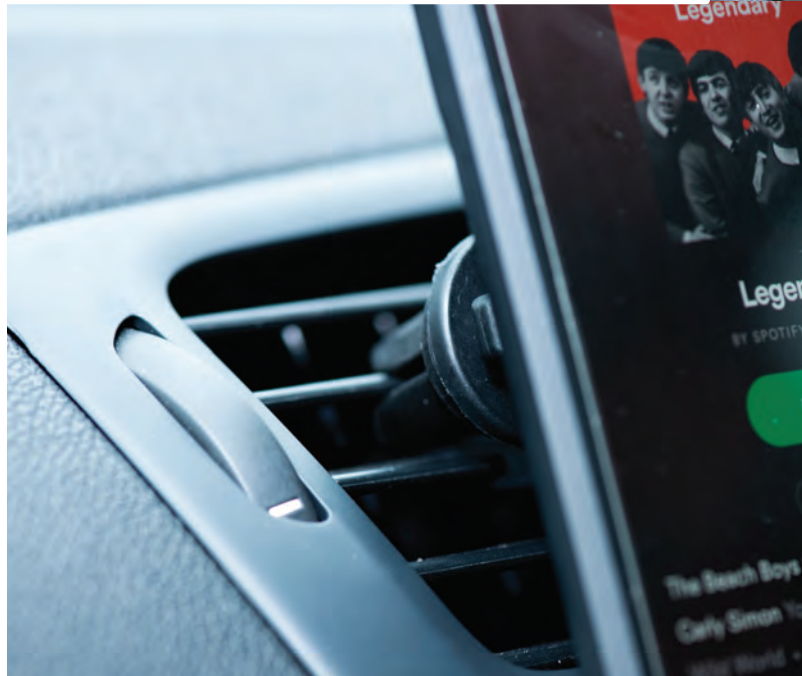

HEAVY DUTY SURFACE MOUNT

The CLIQR Heavy Duty Surface Mount allows you to attach your device to any flat surface, such as motorcycle fairings, dashboards, surfboards, or even around the house. Designed to withstand the extreme forces of extreme sports.

INCLUDES

- 1 x Mount
- 2 x Device adaptors
- 1 x Alcohol wipe

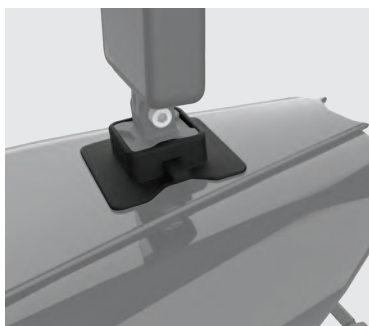

CODE	DESCRIPTION
OX861	Heavy Duty Surface Mount CLIQR



HANDLEBAR ACCESSORIES

SURFACE DEVICE MOUNT

The CLIQR Surface Mount uses powerful 3M™ VHB tape to attach to any flat surface, such as motorcycle fairings, dashboards, surfboards, or even around the house.

INCLUDES

- 1 x Mount
- 2 x Device adaptors
- 1 x Alcohol wipe



CODE	DESCRIPTION
------	-------------

OX858	Surface Mount CLIQR
-------	---------------------



NEW PHONE CASE

A universal touch-screen phone case compatible with the Oxford CLIQR mounting system. Featuring a water-resistant screen and charging capability, Oxford's latest offering from the CLIQR range enables you to mount your device securely and keep it charged whilst on the move.

INCLUDES

- 1 x Phone case
- 1 x Silicone phone holder
- 1 x 8mm foam spacer



CODE	DESCRIPTION
------	-------------

OX868	Phone Case
-------	------------



DEVICE ADAPTORS

Additional device adaptors for those with multiple devices to mount.

FEATURES

- Universal adaptor with VHB 3M™ tape
- Compatible with most phones, phone cases, GPS devices and compact action cameras
- Easy to install
- 2kg weight limit

INCLUDES

- 2 x Device adaptors
- 1 x Alcohol wipe



CODE	DESCRIPTION
------	-------------

OX849	Device Adaptor CLIQR
-------	----------------------

HEAVY DUTY ADAPTORS

Designed for those who want extra security when using large phones or tablets.

FEATURES

- Universal adaptor with VHB 3M™ tape
- Compatible with most phones, phone cases, tablets, GPS devices and compact action cameras
- 8kg weight limit
- Easy to install

INCLUDES

- 1 x Device adaptors
- 1 x Alcohol wipe



CODE	DESCRIPTION
------	-------------

OX855	Heavy Duty Adaptor CLIQR
-------	--------------------------

STRAP-NAV

Handlebar mountable sat-nav holder

FEATURES

- Fixes to motorcycle/bicycle using two hook and loop straps which can be adapted to fit any type of handlebar
- Double layer construction for maximum weather resistance
- Fits Sat-Nav devices measuring up to 145mm (W) x 95mm (H) x 30mm (D)
- Concealed power outlet for routing power cable/headphones (Sat-Nav not included)
- Easy access zip so you can quickly remove Sat-Nav when not in use



CODE	DESCRIPTION
OX558	Strap-Nav

DRYPHONE PRO

Waterproof handlebar mounted phone case

FEATURES

- Waterproof design (IP6 rated)
- Touchscreen compatible
- Suitable for Samsung S8 & S9
- Fingerprint scanner compatible (iPhone & Samsung S8/S9 models only)
- Fits 22.2 - 31.8mm \varnothing handlebars
- Perfect for navigation
- Simple installation
- Available in a selection of sizes for Samsung and iPhone



CODE	DESCRIPTION
OX179	Samsung S8/S9
OX188	Samsung S8+/S9+
OX189	iPhone X/XS
OX198	iPhone 5/5SE/5S
OX199	iPhone 6+/7+/8+



DRYPHONE UNIVERSAL

Waterproof phone case

FEATURES

- Suitable for a wide selection of phones (up to 165 x 80 x 9mm)
- Easily fits to handlebar or stem
- Allows continued use of touch screen
- Angle adjustable mount
- Perfect for navigation or tracking routes
- Installation guide and detachable lanyard included
- Bracket inserts to protect handlebars: Large for 31.8mm handlebars (1 1/2"), Small for 22.2mm handlebars (7/8")



CODE	DESCRIPTION
OX190	Dryphone Universal



HELMET ACCESSORIES



LID LOCKER

Weatherproof lockable helmet bag

Finally an answer to the question: how to leave your helmet with your bike without it getting wet, damaged or stolen? With the Oxford Lid Locker the helmet remains completely protected from the elements at all times. Thread your down a waterproof tube that runs through the visor aperture and out of the bottom of the helmet so that you can lock it to the bike.

FEATURES

- Handy "hook & loop" hanging strap to keep your helmet off the wet ground
- Compatible with most chains and cable locks up to 40mm diameter

NOTE: Does not include lock.

CODE

OX624



LIDLOCK

Combination carabiner helmet lock

FEATURES

- Lightweight aluminium carabiner to attach to the helmet's D-rings
- Special T-Bar designed for helmets with quick release buckle
- Integrated coiled cable, perfect for securing clothing
- Innovative outward-opening carabiner mechanism for ease of use



CODE

OX656



HELMET HALO

Helmet servicing pad

FEATURES

- Soft touch helmet servicing pad
- Protects your helmet's paintwork when not in use
- Suitable for Flip front, Open face, MotoX and Full face helmet designs
- Allows lining to aerate



CODE

OX633

HELMET ACCESSORIES

HELMET CARE KIT

Essential cleaning & anti-fog treatments

FEATURES

- Clean and remove odour and bacteria from the lining of your helmet
- Remove road dirt, insects and grease from your helmet & visor
- Reduce fogging on inside of visor
- Soft microfibre cloth to apply products
- All packed in a convenient black EVA case

CONTAINS:

- Helmet Sanitiser 100ml
- Anti Fog Spray 50ml
- Helmet & Visor Cleaner 50ml
- Microfibre Cloth
- Carry Case



CODE

OX634

LID STRAP

Universal helmet carry strap

FEATURES

- Secure D-ring attachment
- Fully adjustable strap with air mesh padding for extra comfort
- Frees up space in your motorcycle luggage



CODE

OX807





NEW ULTRA CLEAR PRO

Premium anti-fog visor insert

FEATURES

- Fits most helmets
- Silicone seal creating double shield system
- Proven in all weathers
- Easy to use, clean and re-use
- Tack free
- Track tested

CODE

OX696

ULTRA CLEAR

Anti-fog visor insert

FEATURES

- Fits most helmets
- Proven in all weathers
- Easy to use, clean and reuse
- Tack free
- Track tested

CODE

OX632



EAR PLUGS

Multipack of high performance earplugs

SNR 37

- Noise reduction: SNR 37dB
- Self moulding Polyurethane foam
- Protective pocket case
- 50 pairs per pack

SNR 39

- Noise reduction: SNR 39dB
- Self moulding Polyurethane foam
- Protective pocket case
- 50 pairs per pack

SNR 35

- Noise reduction: SNR 35dB
- Self moulding Polyurethane foam
- Protective pocket case
- 100 pairs per pack

CODE DESCRIPTION

OX626 Earplugs SNR 37

OX625 Earplugs SNR 39

OX628 Earplugs SNR 35

A blue and yellow Suzuki motorcycle is positioned inside the cargo area of a van. The motorcycle is secured with grey ratchet straps. The van's interior walls are lined with light-colored wood paneling. The van's rear door is open, and the exterior is a light blue color. The text "TRAVEL & TRANSPORT" is overlaid in white on a blue background across the middle of the image. The Suzuki logo is visible on the motorcycle's fairings.

TRAVEL & TRANSPORT

WWW.

MAGNIMATE

Magnetic side stand support

The unique design of the MagniMate deluxe stand support means you can park your motorcycle on soft ground, safe in the knowledge that the wide base, with integrated magnet and rugged grips, will support it securely.

FEATURES

- Magnet located inside
- Stay safe on soft ground
- 10 grippers on base



CODE

OX749



NEW PADDOCK MATE XL

Extra large side stand support

FEATURES

- Extra large size to accommodate side stands with large feet
- Small enough to keep with you at all times, in case of need
- Made from lightweight but tough ABS plastic, with grip strips on the underside
- 130x70mm



CODE

OX102



PADDOCK MATE

Side stand support

FEATURE

- Help to keep your motorcycle upright when all around are falling
- Made from tough ABS plastic with circular grippers on the base



CODE

OX103



TRAVEL & TRANSPORT

RIDER GRIPS

Secure passenger grab handles

FEATURES

- Comfortable & ergonomic design for the rider
- Fully adjustable double belt system
- Mesh inner lining to increase breathability
- Independently strength tested for your reassurance
- Constructed using high strength bonded nylon thread
- 3M™ high visibility reflective piping
- Reflective logo
- Unique Oxford design



CODE

OX740



FIRST AID KIT CE

Motorcycle first aid kit

FEATURES

- DIN 13167-2014 standard
- Ultra compact, fits under most motorcycle seats
- Hygienically sealed contents
- Approved for motorcycle use

INCLUDES

- Sealable carry case
- 1 x Adhesive plaster tape
- 8 x Adhesive plaster bandages
- 2 x Sterile bandages
- 1 x First aid blanket
- 1 x Sterile compress (burn dressings)
- 1 x Scissors
- 4 x Disposable gloves
- 1 x First aid kit manual



CODE

OX741

CAM STRAPS

Cam buckle tie-down straps



FEATURE

- TÜV tested/approved
- 2 x 180cm straps included
- Max load 150kg (per strap)
- Ideal for securing and anchoring luggage



CODE

OX745

CARGO NETS

Elasticated luggage net

CARGO NET

- Strong elasticated webbing
- Nylon coated steel hooks
- Size:
Standard - 30 x 30cm (relaxed)
XL: - 43 x 43cm (relaxed)

BRIGHT NET

- Unique reflective construction for visibility
- Strong elasticated webbing
- Nylon coated steel hooks
- Size: Standard - 38.1 x 38.1cm (relaxed)



CODE	DESCRIPTION
OX663	Cargo Net - Black
OX664	Cargo Net - Red
OX665	Cargo Net - Blue
OX666	Cargo Net - Black XL

CODE	DESCRIPTION
OX658	Bright Net - Black
OX659	Bright Net - Yellow

BUNGEEES

Elasticated reflective luggage net

FEATURES

- Attach to secure mounting points, such as dedicated luggage hooks, solid footrest brackets or parts of the frame
- Hardened steel hooks for optimum strength
- Rubber ends protects paintwork

BUNGEE

CODE	DESCRIPTION
OX706	10x450mm / 18"
OX707	10x600mm / 24"
OX708	10x750mm / 30"
OF434	10x900mm / 36"

BUNGEE XTRA

CODE	DESCRIPTION
OX712	16x600mm / 24"
OX713	16x800mm / 32"
OX714	16x900mm / 36"

BUNGEE XTEND

CODE	DESCRIPTION
OX716	8x800mm / 32"



BUNGEE

BUNGEE XTRA

BUNGEE XTEND

DOUBLE BUNGEE



DOUBLE BUNGEE

CODE	DESCRIPTION
OX715	2x9x600mm / 24"

TWIN FLAT WIRE BUNGEE

CODE	DESCRIPTION
OX717	16x600mm / 24"
OX718	16x800mm / 32"
OX719	16x900mm / 36"



TWIN FLAT WIRE BUNGEE

CARABINER

Multi-use carabiner

FEATURES

- Simple to use
- Ideal to clip keys onto
- Use to hang items from your rucksack
- Lightweight alloy 17.3g
- Dimensions: 78 x 43 x 7mm

Not PPE or for climbing



CODE	DESCRIPTION
OXCA	Carabiner (100pk)



TRAVEL & TRANSPORT

BAR STRAP KIT

Handlebar tie-down harness & straps

FEATURES

- Integrated cam buckle straps eliminate the need for conventional strapping
- Wide cam buckle straps designed for reliability over and above ratchet straps
- High tensile carabiner hooks guarantee fast and secure fitting
- Padded shoulder strap
- Hand loops fitted to allow maximum tensioning
- Soft fleece pads to prevent scratching of paintwork



CODE
OX747



BAR STRAP HARNESS

Handlebar tie-down harness

FEATURES

- Makes attaching bikes to trailers easier and safer
- Suitable for most motorcycles, including Moto-X, road bikes and ATV's
- Tough flag stitched webbing provides strength, thick fleece prevents paint wear
- 4.5cm wide nylon webbing
- Use in conjunction with S-Hook Straps (OX742)



CODE
OX746



RATCHET HOOK STRAPS

Heavy duty ratchet straps

FEATURES

- Safe working load: 196kg
- 25mm width Nylon webbing
- Coated S hooks
- Extra secure and safe fixing loop
- Extension loops eliminates direct contact between hook and bike



CODE
OX744



S-HOOK STRAPS

Self locking tie-down S-hook straps

FEATURES

- 2 x 2m top quality 1" nylon webbing
- Safe working load: 105kg
- Rubber coated S-Hooks
- Extra fixing loops to protect paintwork

CODE

OX742



CARABINER STRAPS

Self-locking tie-down carabiner straps

FEATURES

- 2 x 2m top quality 1" nylon webbing
- Safe working load: 91kg
- Rubber coated S-Hooks
- Extra strong carabiner clip
- Extension loops eliminates direct contact between hook and bike

CODE

OX743

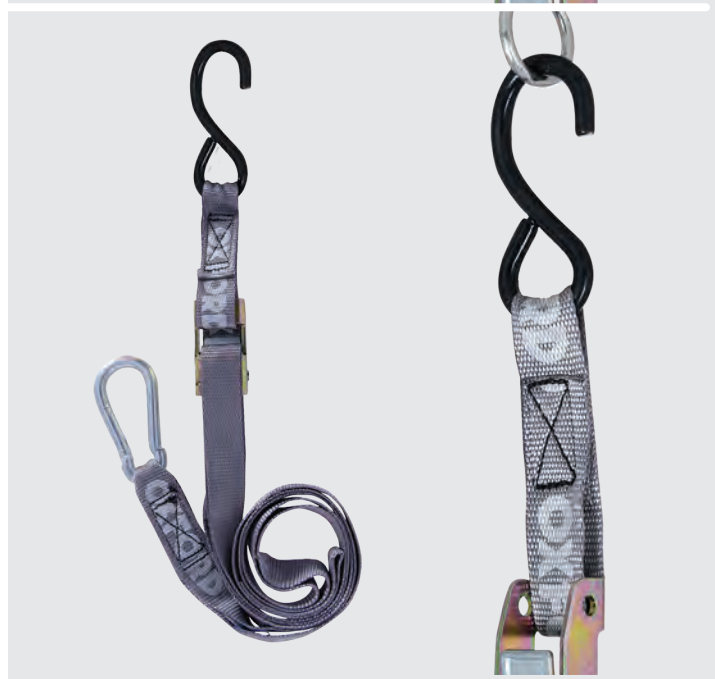

RAMP

Lightweight aluminium loading ramp

FEATURES

- Designed for use with bikes up to 340kg
- Wide design is ideal for use by 1 person
- Folding construction for easy storage
- Hook & loop strap keeps ramp safely closed whilst carrying
- Can hook onto a 13mm / 1/2" bar on the tail of pick-up truck
- PVC coated resting forks to avoid scratching vehicle
- Includes webbing strap to hold ramp to vehicle
- Dimensions: 2.1m / 7ft long x 27.5cm / 11" wide

Save your bike, save your thigh. Buy a proper ramp, like this Oxford one. It folds, taking up less space in your van/garage, it has a nice curve so you don't drag your undercarriage, and it has grippy 'fingers' at the end to prevent slippage.

SuperBike

CODE

OX748



LUGGAGE



IN THE BEGINNING WAS THE TOP BOX

Oxford's very first product back in 1973 was a top box... tough, secure, watertight, no-nonsense. Today, our luggage range is huge, varied and endlessly versatile, but remains true to the simple charms of that first top box. With shapes and styles to suit all types of motorcycle, we excel in producing well thought-out, reliable kit and really do have a solution for carrying all of your kit - on and off the bike.

ALWAYS DEVELOPING

Motorcycle luggage exists in a harsh environment, attacked at high speeds by all weather conditions. It must be made from durable, weatherproof material and have lots of useful features. It needs to be adjustable, so that it can be fitted to a wide variety of machines. It also needs to offer decent carrying capacity and to look good on the bike.

Oxford's luggage is always developing; every year we hunt down the latest technology, innovate new solutions and build more functionality into our designs. From humble top box beginnings, Oxford has become the world's leading soft motorcycle luggage brand. Explore our range, then explore with us.



AQUA



S-SERIES



R-SERIES



HERITAGE



F1



TANK BAG QUICK RELEASE MECHANISM

- Simple auto-attach / lever-pull release
- Featuring a unique safety mechanism
- Available in multiple colourways

CODE	DESCRIPTION
OL280	Type 1 qr tank adaptor
OL281	Type 2 qr tank adaptor
OL282	Type 3 qr tank adaptor
OL283	Type 4 qr tank adaptor
OL284	Type 5 qr tank adaptor
OL279	Type 6 qr tank adaptor
OL278	Type 7 qr BIKE adaptor (HONDA)

QR SYSTEM Head to oxfordluggage.com for our full compatibility chart

STEP 1

Buy a QR tankbag or upgrade your existing tankbag with a compatible QR base



STEP 2

Buy and fit the QR tank ring adaptor which is compatible with your motorcycle

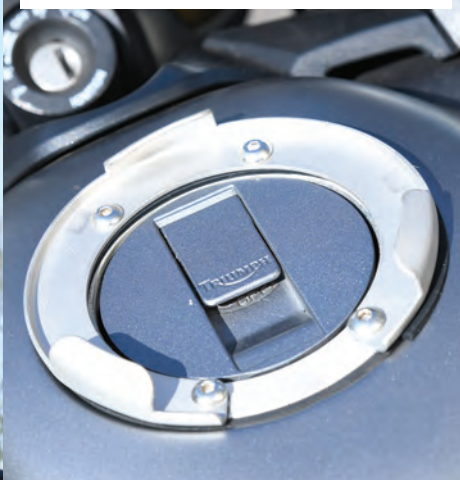

STEP 3

Fit bag by clicking into place



IMPORTANT INFO:

- Because we ride bikes we understand that motorcycle luggage needs to be adjustable, so that it can be fitted to a wide variety of machines and must be made from durable, weatherproof material. It also needs to offer decent carrying capacity and to look good. We are never complacent and every year we build more features into our design. All this explains why we are today a successful global motorcycle luggage brand.
- OXFORD LIFETIME LUGGAGE is designed by motorcyclists in the UK. We are so confident of its quality and durability that we guarantee it against faulty manufacture or materials for life! The Lifetime Guarantee does not, however, extend to rain covers, buckles and zip tags, which are covered under our usual warranty. Nor does it insure against reasonable wear and tear or failure to properly care for/maintain the product.
- Read the user recommendations carefully before use to enjoy this luggage safely and to its full capacity.
- If you need advice on which bags are best suited to your riding needs, please don't hesitate to call our customer services team on 01993 862 300.

Full details and model application list available at www.oxfordproducts.com/luggage



AQUA

WEATHERPROOF BAGS

Oxford's Aqua bags are one of the easiest ways to get your gear from A to B on a motorcycle, safe and dry. They are made from a tough PVC tarpaulin, which is welded to form waterproof seams. When straps are added to perform essential functions (such as securing the bag onto a motorcycle), Oxford uses innovative construction techniques to further reinforce the bag whilst ensuring complete waterproofing.

The latest generation of Oxford's acclaimed Aqua luggage now offers a choice of five useful tail bag sizes - from commuter 8L through to 'epic voyage' 70-litre versions - plus a range of backpacks and tank bags



"The middle sized of Oxford's Aqua packs is great value and arguably the most practical." AQUA-T 50

Ease of fitting: 4
Stability: 5
Loading: 4
Waterproofing: 5

RIDE

"Swallows up your weekend gear...
...It's a great bit of kit." AQUA-T 30

Tester: Alison Silcox
Time tested: 700 miles

MCN

AQUA ROLL BAGS

FEATURES

- Easy grab carry handle
- Waterproof roll top closure
- External and internal pockets for small items
- Reflective detailing for improved visibility
- Suitable for use on motorcycles
- Wipe-clean, waterproof construction with welded seams
- Padded shoulder strap for added comfort
- Unique attachment system for motorcycles with underseat security strap
- Compression straps for maximum stability

AQUA T70

70L Capacity

Approx size when filled: 40 x 65 x 38cm

COLOUR OPTIONS



AQUA T50

50L Capacity

Approx size when filled: 35 x 60 x 34cm

COLOUR OPTIONS



AQUA T30

30L Capacity

Approx size when filled: 34 x 50 x 28cm

COLOUR OPTIONS



AQUA T20

20L Capacity

Approx size when filled: 30 x 40 x 26cm

COLOUR OPTIONS



CODE	DESCRIPTION
OL453	Aqua T70 - Black
OL483	Aqua T70 - Black/Grey
OL402	Aqua T50 - Khaki/Black
OL452	Aqua T50 - Black
OL462	Aqua T50 - Black/Grey/Fluo
OL482	Aqua T50 - Black/Grey
OL492	Aqua T50 - White/Grey

CODE	DESCRIPTION
OL401	Aqua T30 - Khaki/Black
OL451	Aqua T30 - Black
OL461	Aqua T30 - Black/Grey/Fluo
OL481	Aqua T30 - Black/Grey
OL450	Aqua T20 - Black



LUGGAGE

AQUA M8

8L magnetic tank bag



FEATURES

- Waterproof roll top closure
- Wipe-clean, waterproof construction with welded seams
- Large, clear 170mm x 90mm touch compatible window with deep pocket behind
- Water resistant pocket zip
- Moulded easy grab carry handle
- Reflective detailing
- Compression straps for secure fastening
- Headstock strap included (must be used)

Approx size when filled: (HxWxD) 30 x 18 x 12cm



CODE	DESCRIPTION
OL404	Aqua M8 - Khaki/Black
OL454	Aqua M8 - Black
OL464	Aqua M8 - Black/Grey/Fluo

AQUA T8

8L strap-on tail bag



FEATURES

- Waterproof roll top closure tail pack
- Wipe-clean, waterproof construction with welded seams
- Mesh see-through window pocket for small items with 2nd deep pocket behind
- Moulded easy grab carry handle
- Water resistant pocket zip
- Reflective detailing for improved visibility
- Compression straps for secure fastening

Approx size when filled: (HxWxD) 30 x 18 x 12cm



CODE	DESCRIPTION
OL405	Aqua M8 - Khaki/Black
OL455	Aqua M8 - Black
OL465	Aqua M8 - Black/Grey/Fluo

AQUA S8

8L strap-on tank bag



FEATURES

- Waterproof roll top closure with tension straps
- Wipe clean, waterproof construction with welded seams
- Reflective detail for improved visibility
- Large, clear 170mm x 90mm touch compatible window with deep pocket behind
- Strap on harness with zip attachment
- Headstock safety strap (must be used)
- Easy grab moulded carry handle

Approx size when filled: (HxWxD) 34 x 24 x 12cm



CODE	DESCRIPTION
------	-------------

OL756	Aqua S8 - Black
-------	-----------------

AQUA M2

2L magnetic tank bag



FEATURES

- Waterproof roll top closure with tension straps
- Wipe clean, waterproof construction with welded seams
- Reflective detail for improved visibility
- Headstock safety strap (must be used)
- Suitable for use on motorcycles with steel fuel tanks
- Magnetic base
- Waterproof internal pocket with window section

Approx size when filled: (HxWxD) 27 x 24 x 8cm



CODE	DESCRIPTION
------	-------------

OL757	Aqua M2 - Black
-------	-----------------

LUGGAGE

AQUA P32

16L strap-on pannier



FEATURES

- Waterproof roll top closure with tension straps
- Bespoke safety attachment system
- Shoulder strap
- Reflective detail for improved visibility
- Internal pocket with water resistant zip for small items
- Wipe clean, waterproof construction with welded seams

Approx size when filled: (HxWxD) 26 x 40 x 8cm



CODE	DESCRIPTION
OL755	Aqua P32 - Black

AQUA L1

1L leg bag



FEATURES

- Waterproof roll top closure with tension straps
- Wipe clean, waterproof construction with welded seams
- Reflective detail for improved visibility
- Adjustable waist and leg strap (up to 50 inch waist)
- Comfortable to wear
- External pocket with waterproof zip

Approx size when filled: (HxWxD) 17 x 16 x 7cm



CODE	DESCRIPTION
OL758	Aqua L1 - Black



AQUA B25

25L backpack

FEATURES

- Now includes large pocket for hydration system
- Extra deep front pocket with water resistant zip
- Restyled design and branding
- Adjustable compression chest and waist straps
- Removable padded waist belt
- Waterproof roll top closure
- Wipe-clean, waterproof construction with welded seams
- Reflective detailing for improved visibility
- Compression straps for maximum stability

Approx size when filled: (HxWxD) 50 x 28 x 20cm



CODE	DESCRIPTION
OL406	Aqua B25 - Khaki/Black
OL456	Aqua B25 - Black
OL466	Aqua B25 - Black/Grey/Fluo
OL476	Aqua B25 - Black/Fluo

LUGGAGE



AQUA EVO

12L and 22L waterproof backpacks

22L FEATURES

- Super lightweight rip-stop material
- Roll top backpack with side compression straps
- Waterproof rating IPX-6
- Airtech back system improves air flow circulation and comfort
- Front external water resistant pocket
- Highly reflective details
- Reflective loops at the base to attach taillights
- Carry handle
- Removeable padded laptop sleeve

Approx size when filled: (HxWxD) 46 x 39 x 14cm

12L FEATURES

- Super lightweight rip-stop material
- Roll top backpack with side compression straps
- Waterproof rating IPX-6
- Airtech back system improves air flow circulation and comfort
- Front external water resistant pocket
- Highly reflective details
- Reflective loops at the base to attach taillights
- Carry handle

Approx size when filled: (HxWxD) 43 x 32 x 11cm

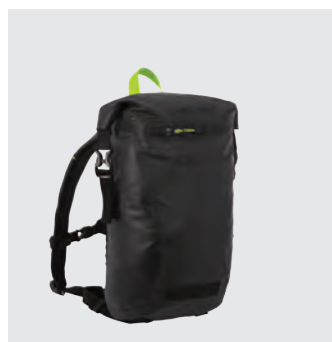

CODE	DESCRIPTION
------	-------------

OL686	Aqua EVO - 22L
-------	----------------

OL685	Aqua EVO - 12L
-------	----------------



AQUA V20 + V12

12L and 20L waterproof backpacks

20L FEATURES

- Waterproof roll top closure
- Physibility - 360 degree reflective detailing
- 3x air mesh panels for greater air circulation and comfort
- Water resistant zipped external pockets
- Wipe clean, waterproof construction with welded seams
- Reflective webbing loop for tail light attachment

Approx size when filled: (HxWxD) 50 x 20 x 23cm

12L FEATURES

- Waterproof roll top closure
- Physibility - 360 degree reflective detailing
- 2x air mesh panels for greater air circulation and comfort
- Water resistant zipped external pockets
- Wipe clean, waterproof construction with welded seams
- Reflective webbing loop for tail light attachment

Approx size when filled: (HxWxD) 40 x 24 x 12cm



CODE	DESCRIPTION
OL691	Aqua V12 - Black
OL693	Aqua V12 - Fluo
OL694	Aqua V12 - Orange
OL695	Aqua V20 - Black
OL697	Aqua V20 - Fluo
OL698	Aqua V20 - Orange



S-SERIES

SEMI-RIGID LUGGAGE

Oxford's new S-Series motorcycle luggage combines tough construction with clean styling and quick-release convenience.

You can enjoy the benefits of both hard and soft luggage with Oxford's latest innovation.

Soft-touch materials are formed into a rigid construction using advanced vac-forming processes. This creates stylish, wipe-clean surfaces and crisp shapes which complement the lines of the motorcycle, yet you retain the easy-to-live-with qualities of soft bags.

The well-organised storage compartments are easy to access through weather-resistant zips and all bags come with rapid attachment/detachment systems.

TANK AND TAIL BAG FEATURES



Weather resistant zips



Reflective piping

- 5kg max load
- EVA body, 600D polyester fabric base
- Slim ergonomic TPR handle

T5S

5L tail pack



FEATURES

- Twin moulded top + base for added strength
- Adjustable cargo net for small items, internal zipped mesh net pocket in lid
- G-hook tension lock slider straps for securing under seat
- Protective cloth storage bag and rain cover included

(HxWxD) 13.5 x 28 x 28cm



CODE	DESCRIPTION
OL528	S-Series - T5S

M4S & Q4S

4L tank bags



FEATURES

- Nylon 210D lining
- Internal zipped mesh net pocket
- 4 loops to attach phone holder (sold separately)
- Cable port entry/outlet front & rear
- Headstock strap provided (must be used)
- Protective cloth storage bag and rain cover included
- Choose from magnetic or QR fitment

M4S: 13 x 21 x 21cm

Q4S: 15 x 21 x 21cm

(HxWxD)



CODE	DESCRIPTION
OL526	S-Series - M4S
OL525	S-Series - Q4S

P4S

Phone holder

FEATURES

- Works with facial recognition
- Touch screen compatible
- For use with Q4S & M4S tank bags
- Hook and loop fastenings front and rear

Fits phone of up to approximately:

Height: 16cm, Width: 8cm



CODE	DESCRIPTION
OL527	S-Series - P4S



R-SERIES

LUGGAGE

Oxford's Lifetime Luggage is the jewel in its crown, benefiting from 20+ years of passionate development since its launch in 1997.

Most bags look roughly the same from the outside, differentiated only by the styling, number of pockets and a few handy features.

The difference between a good bag and a GREAT bag is what you don't see at first glance; the material composition, construction methods, waterproofing systems, safety mechanisms, tried and tested componentry and built-in real-world usability.

You don't need to know what Oxford's test laboratory has specified, amongst other things: flag-stitched stress points; taped waterproof liners; innovative and over-engineered security straps; tough outer materials to battle the elements; soft touch-point materials to protect your bike; bright interiors for better content visibility; self-healing zippers; comprehensive user guidelines.

You'll carry on not needing to know for years and years... which is why Oxford Lifetime Luggage comes with an unparalleled Lifetime Guarantee.

RIDER
MAGAZINE

RECOMMENDED

P60R / P50R

60/50L panniers



STRAP-ON

An extremely versatile set of panniers. Perfect for naked bikes, tourers and sports tourers and for those that need a lot of flexibility in their luggage.

FEATURES

- **FIRETEX** Heat resistant base in case of momentary contact with the exhaust
- Large top opening and 360 degree opening zips for easy access to contents
- Rubberised side panel helps to protect the paintwork
- External net for wet items and internal net pocket
- 7 Point secure fitting system
- Made from a tough Ripstop Nylon
- Removable waterproof liner

CODE DESCRIPTION

OL315 R-Series - P50R Black

OL316 R-Series - P50R Red

OL317 R-Series - P50R Blue

OL305 R-Series - P60R Black

P50: 32x23x48cm

P60: 28x23x58cm

(hxwxd)



M40R

40L magnetic tank bag



MAGNETIC

Stylish, multi-functional, magnetic tank bag with a whole host of innovative features. Suitable for most motorcycles with steel tanks. Includes map and SatNav holder. Big enough to carry a full face helmet when expanded, it is equally capable of swallowing up enough gear for a weekend away.

FEATURES

- Anti-glare pocket for GPS devices, smart phones and maps
- Water resistant electrical port (with internal pocket to carry device)
- Headstock safety strap provided (must be used)
- Converts into a backpack
- Additional zip compartment in base
- Made from a tough Ripstop Nylon
- Removable waterproof liner
- Key pocket

CODE DESCRIPTION

OL205 R-Series - M40R

32x22x35cm

(hxwxd)



T40R

40L tail pack



STRAP-ON

The most sophisticated of seat bags is packed with useful and innovative features. Big enough to carry a full face helmet when expanded, it is equally capable of swallowing up enough gear for a weekend away.

FEATURES

- Glove compartment and external bungee net
- Internal mesh pocket
- Key pocket
- 5 point secure fitting system
- Secure mounting points
- Unzip main bag to convert in to a backpack, revealing map holder
- Made from a tough Ripstop Nylon
- Removable waterproof liner
- Quick unzip base to used on its own to carry small items

CODE DESCRIPTION

OL325 R-Series - T40R

32x22x35cm

(hxwxd)



LUGGAGE

M30R/S30R/Q30R

30L tank bags

FEATURES

- Anti-glare pocket for GPS devices, smart phones and maps
- Water resistant electrical port
- Headstock safety strap (must be used)
- Additional zip compartment in base
- Unzip main bag to convert in to a backpack, revealing map holder. (S30R + M30R only)
- Made from a tough Ripstop Nylon
- Key pocket
- Removable waterproof liner



STRAP-ON



MAGNETIC



CODE	DESCRIPTION
OL345	R-Series - S30R
OL245	R-Series - M30R Black
OL246	R-Series - M30R Red
OL247	R-Series - M30R Blue
OL270	R-Series - Q30R

30x18x36cm
(hxwxd)

T30R

30L tail pack

This expandable tail pack is the perfect size and shape for modern sports bikes and sport tourers, an extremely versatile must-have piece of equipment! Once securely attached in place, it can be quickly removed and re-fitted using the zip-off base facility.

FEATURES

- Glove compartment and external bungee net
- Unzip main bag to convert in to a backpack, with handy pocket for small items
- 5 point secure fitting system
- Quick unzip base to used on its own to carry small items
- Made from a tough Ripstop Nylon
- Key pocket
- Removable waterproof liner



STRAP-ON



CODE	DESCRIPTION
OL335	R-Series - T30R Black
OL336	R-Series - T30R Red
OL337	R-Series - T30R Blue

32x18x38cm
(hxwxd)

T25R

25L helmet carrier tail pack

An easy access tail bag which doubles as a deluxe helmet carrier and is very easy to fit. It is constructed with the same exceptional materials and build quality as the rest of the R-Series luggage range. Comes complete with a shoulder strap and universal fitment system for the rear seat of most motorcycles.

FEATURES

- Glove compartment and external bungee net
- Two large side pockets ideal for carrying helmet accessories
- Internal padding
- Shoulder strap
- Made from a tough Ripstop Nylon
- Key pocket



STRAP-ON



CODE	DESCRIPTION
OL338	R-Series - T25R

25x28x32cm
(hxwxd)

S20R / Q20R

20L adventure tank bags

A tank bag packed with all of Oxford's usual excellent features, it is specially sculpted to fit the cut-away shape found on most adventure bikes' tanks. Comes in strap-on and quick release versions.

FEATURES

- Anti-glare pocket for GPS devices, smart phones and maps
- 5 point secure fitting system
- Unzip main bag to convert in to a backpack, with handy pocket for small items
- Made from a tough Ripstop Nylon
- Key pocket
- Quick unzip base to used on its own to carry small items

CODE DESCRIPTION

OL231	R-Series - S20R	32x12x35cm
OL241	R-Series - Q20R	(hxwxd)



Night away: Just enough room to fit the gear in for a night away. In a line: Pricey, but a great looking tank bag with some good features.



M15R / Q15R

15L tank bags

This smaller tank bag is perfectly proportioned for everyday use on a huge range of bikes.

FEATURES

- Water resistant electrical port (with internal pocket for devices)
- Anti-glare pocket for GPS devices, smart phones and maps
- Headstock safety strap (must be used)
- Additional zip compartment in base
- Unzip from base for quick get-away
- Made from a tough Ripstop Nylon
- Key pocket
- Removable waterproof liner

CODE DESCRIPTION

OL221	R-Series - M15R	32x17x32cm
OL216	R-Series - Q15R	(hxwxd)



M4R / Q4R

4L tank bags

The magnetic M4R can be used as both a tank bag and tail pack. Compact for use on any bike, yet large enough to hold the essentials for a day's riding.

The Q4R is a quick release tank bag, with all the same features.

FEATURES

- Water resistant electrical port (with internal pocket for devices)
- Anti-glare pocket for GPS devices, smart phones and maps
- Headstock safety strap (must be used)
- Made from a tough Ripstop Nylon
- Key pocket

CODE DESCRIPTION

OL255	R-Series - M4R Black	20x14x28cm (hxwxd)
OL256	R-Series - M4R Red	
OL257	R-Series - M4R Blue	
OL290	R-Series - Q4R Black	
OL291	R-Series - Q4R Red	
OL292	R-Series - Q4R Blue	



LUGGAGE

M2R

2L tank bags

Fits steel tanks where no other tank bag will, thanks to its unique shape and size. Ideal for a wide range of motorcycles, including super sports, cruisers and even some trail bikes.

FEATURES

- Water resistant electrical port (with internal pocket for devices)
- Anti-glare pocket for GPS devices, smart phones and maps
- Carry handle & headstock safety strap (must be used)
- Front zipped pocket
- Made from a tough Ripstop Nylon
- Key pocket

14x19x28cm
(hxwxh)

CODE DESCRIPTION

OL354	R-Series - M2R Black
OL355	R-Series - M2R Red
OL356	R-Series - M2R Blue



M1R

1L tank bags

Oxford's smallest ever tank bag, offering just enough space for your ride-out essentials: phone, wallet, visor cleaner, earplugs, etc. Its tiny size means it can fit any motorcycle with a steel tank.

FEATURES

- Water resistant electrical port (with internal pocket for devices)
- Anti-glare pocket for GPS devices, smart phones and maps
- Carry handle & headstock safety strap (must be used)
- Made from a tough Ripstop Nylon
- Water resistant zips

14x18x24cm
(hxwxh)

CODE DESCRIPTION

OL351	R-Series - M1R Black
OL352	R-Series - M1R Red
OL353	R-Series - M1R Blue



L1R

1L leg bag

FEATURES

- Easy to attach
- Comfortable to wear
- External pocket
- Great way to keep your essentials safe
- Adjustable straps
- Weather resistant zips
- Reflective detail

CODE DESCRIPTION

OL239	R-Series - L1R
-------	----------------

21x16x8cm
(hxwxh)



XW3R

3L waist bag

FEATURES

- Reflective logo/detailing
- Adjustable straps to secure
- Padded back section for additional comfort
- Main compartment plus 3x external pockets
- Weather resistant zips
- Adjustable waist strap (up to 56")

CODE	DESCRIPTION
------	-------------

OL866	R-Series - XW3R
-------	-----------------

15x16x26cm
(hxwxd)



XW1S

1.5L waist bag

FEATURES

- Reflective logo/detailing
- Adjustable straps to secure
- Padded back section for additional comfort
- Main compartment plus external pockets
- Adjustable waist strap (up to 56")
- Material: 600D Polyester and Ripstop fabric

CODE	DESCRIPTION
------	-------------

OL867	R-Series - XW2S
-------	-----------------

13x19cm
(hxw)



XB25S

25L backpack

FEATURES

- Integrated helmet carrier with drawstring and snap buckle closure to secure
- Aerodynamic design to reduce drag
- Reflective logo & trims
- Front zipped pocket and two large mesh side pockets
- Padded shoulder straps with small zip pocket for keys or change
- Durable neoprene carry handle
- Two thick padded back sections with air mesh for added comfort and breathability
- Water resistant zips
- Made from 600D Polyester with Ripstop panel detail
- Non-slip PVC base
- Black and reflective waterproof cover

CODE	DESCRIPTION
------	-------------

OL859	R-Series - XB25S
-------	------------------

48x40x25cm
(hxwxd)





HERITAGE

OLD WORLD STYLING, MODERN USABILITY

This vintage-styled waxed poly cotton luggage uses traditional materials and manufacturing techniques to recall a time when people worked and played outdoors, come rain or shine. But hidden beneath the old-world look is a hidden layer of modern technology, to offer a user experience to match today's demanding expectations.

The bags' key material is a dry waxed polycotton, a modern take on the traditional sail cloth which found its way into the clothing which sailors wore to protect themselves from the salt water and wet weather. The dry wax application is applied to all outer materials including the straps and has the very real benefit of not coming off on your hands when moving, fitting and using the luggage.

Respectful of the material's heritage, Oxford's designers have employed traditional methods to assemble the bags. For example, pockets are pleated in order to lie flat when empty, but provide space to expand when full; flag stitches secure all the straps and strapping points to the main structure of the bag; the roll top closure is both traditional and the best way to seal the bags against rain.

Inside the bags, however, you will find a very modern removable waterproof liner which uses taped seams to guarantee that the contents remain dry, even when the outer material has been drenched.

Similarly, the luggage employs Oxford's most up-to-date fitting system to ensure that it can be secured to the bike safely, with all necessary fittings supplied.

The result is a wholly user-friendly product which does the job whilst looking the part.

FEATURES

- Waxed Polycotton outers
- Water resistant roll top closures
- Removable waterproof liners
- Easy grab carry handles

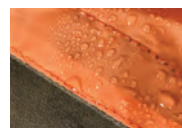

Khaki - Orange Liner



Black - Red Liner

BACKPACK

30L wax polycotton backpack

FEATURES

- Padded shoulder straps for added comfort
- External front pocket with zip and press stud closure
- Removable waterproof liner
- Adjustable chest & waist straps
- Side compression straps

55x30x17cm
(hxwxwd)



CODE	DESCRIPTION
OL570	Heritage Backpack - Black
OL575	Heritage Backpack - Khaki



ROLL BAGS

20, 30 & 50L wax polycotton roll bags

FEATURES

- Padded shoulder straps for added comfort
- External front pocket with zip and press stud closure
- Removable waterproof liner
- All fittings for motorcycles included
- Underseat security strap(must be used)

20L: 26x46x26cm
30L: 26x55x7cm
(hxwxwd)



CODE	DESCRIPTION
OL571	Heritage Roll Bag - Black 20L
OL572	Heritage Roll Bag - Black 30L
OL577	Heritage Roll Bag - Khaki 30L



PANNIERS

40L wax polycotton panniers

FEATURES

- Padded shoulder straps for added comfort
- External front pocket with zip and press stud closure
- Removable waterproof liner
- All fittings for motorcycles included
- Underseat security strap(must be used)
- Stiffening boards helps back and base retain its shape
- Slip-through sleeve on back for sissy bar and tucking away seat straps when using shoulder straps

32x35x17cm
(hxwxwd)



CODE	DESCRIPTION
OL573	Heritage Panniers - Black 40L
OL578	Heritage Panniers - Khaki 40L



LUGGAGE



F1

LUGGAGE

Oxford's F1 luggage provides an economical alternative to the Lifetime range, with all the essential features and a few more besides.

The bags retain all Oxford's approved construction methods, waterproofing systems and safety mechanisms in a wide range of styles and sizes to suit most bikes. The range also boasts a unique feature...

Five colour swatches are provided for you to colour-match to your bike; simply insert your chosen colour into the windows provided!



5 Coloured inserts included with every bag. Simply slide the swatch into the window.

COLOUR OPTIONS



P55 / P45

55/45L strap-on panniers

FEATURES

- Durable rip-stop nylon
- Showerproof inner liner (removable)
- Reflective print
- External pocket
- Expandable
- Unique third seatbelt safety strap secures under the seat
- Shoulder straps and carry handles

CODE	DESCRIPTION
------	-------------

OL444	F1 - P45
-------	----------

OL445	F1 - P55
-------	----------



M35

35L magnetic tank bag

FEATURES

- Durable rip-stop nylon
- Showerproof inner liner (removable)
- Reflective print
- Device & map holder
- Detachable base
- Converts to backpack
- External pocket and carry handle
- Expandable
- Headstock safety strap (must be used)

CODE	DESCRIPTION
------	-------------

OL442	F1 - M35
-------	----------



T35

35L strap-on tail pack

FEATURES

- Durable rip-stop nylon
- Showerproof inner liner (removable)
- Reflective print
- Converts to backpack
- External pocket
- Expandable
- Elasticated netting for stowing lightweight items such as gloves

CODE	DESCRIPTION
------	-------------

OL446	F1 - T35
-------	----------



LUGGAGE

M18 / Q18 / S18

18L tank bags

FEATURES

- Durable rip-stop nylon
- Showerproof inner liner (removable)
- Reflective print
- Carry handle
- External pocket
- Headstock safety strap (must be used)

CODE	DESCRIPTION
OL441	F-1 - M18
OL443	F-1 - S18
OL449	F-1 - Q18



T18

18L tail pack

FEATURES

- Durable rip-stop nylon
- Showerproof inner liner (removable)
- Reflective print
- External pocket
- Detachable base

CODE	DESCRIPTION
OL448	F-1 - T18



M7

7L tank bag

FEATURES

- Durable rip-stop nylon
- Showerproof inner liner (removable)
- Reflective print
- Device & map holder
- External pocket
- Headstock safety strap (must be used)

CODE	DESCRIPTION
OL440	F-1 - M7



JACKETSTASH

Deluxe jacket carrier

FEATURES

- Elasticated netted glove pocket
- Asymmetrical zip for easy access
- Carry handles
- 4 vents for air circulation
- Strong & durable (600D Polyester) construction
- Water resistant
- Inner - PVC Backing
- Outer - 100% Polyester

CODE

OL304

BOOTSTASH

Deluxe padded boot carrier

FEATURES

- Designed to fit all types of boots
- Semi-rigid construction maintains the bag's shape
- Large rear zipped opening for ease of access; flap folds flat to create a changing mat
- Large front pocket for accessories, socks, etc
- Large rear mesh pocket for airing gloves after use
- Carry handle & shoulder strap

CODE

OL263

BOOTSACK

Essential boot carrier

FEATURES

- Designed to fit all types of boots
- Semi-rigid construction maintains the bag's shape
- Large zipped front opening for ease of access
- Large rear mesh pocket for airing gloves after use
- Carry handle

CODE

OL262

DRYSTASH

Waterproof travel roll bags

FEATURES

- Made from tough 600D polyester
- Weatherproof closure system
- Waterproof taped seams
- Padded shoulder strap
- Unique Oxford safety attachment system

T15:
Height: 52cm
Diameter: 25cm

T30:
Height: 58cm
Diameter: 32cm

T45:
Height: 63cm
Diameter: 35cm

CODE DESCRIPTION

OL311 Drystash - T15
OL312 Drystash - T30
OL313 Drystash - T45



LUGGAGE

LIDSACK

Lined helmet carrier

FEATURES

- Made from tough, water resistant, protective fabric
- Carry handles
- Easy access front pocket

CODE

OL261



VISORSTASH XL & T2

Deluxe visor carrier

FEATURES

- Wearable as a belt
- Fits all common visors
- Anti-scratch soft lining
- Water resistant
- The Visorstash T2 has all the features of Visorstash XL but with an added pocket

Dimensions:

18.5 x 55cm



CODE DESCRIPTION

OL301 Visorstash - XL

OL302 Visorstash - T2

LIDSTASH

Deluxe helmet carrier

FEATURES

- Made from tough, water resistant, protective fabric
- Carry handles
- Large 3D zipped external pocket
- Deluxe fleece lining for extra protection
- Shoulder strap (removable)

CODE

OL260



LID STRAP

Helmet carry strap

FEATURES

- Hands-free solution for carrying your helmet when not riding
- Secure D-ring attachment
- Fully adjustable strap with air mesh padding for extra comfort
- Frees up space in your motorcycle luggage
- Not recommended for use when riding

CODE

OL807



TOOLSTASH

Compact tool roll

FEATURES

- Compact tool roll with 34 elasticated tool locations.
- 3-layer padded construction using tough 600D, PVC backed polyester
- Reinforced window pocket for visible 'extras'.
- Steel eyelets to facilitate hanging in a workshop.
- 'Hook-and-loop' fastening compression straps with bar-tack reinforcements.
- Dimensions:
150 x 285 mm (closed)
575 x 285 mm (open)

*TOOLS NOT INCLUDED

CODE

OL259



HANDY SACK

15L backpack

FEATURE HEADER

- Folds away into integral pocket
- Fits under the seat or carry using belt loops provided
- Adjustable padded shoulder straps
- Integral helmet carrier
- Exterior key pocket with carabiner clip
- 15cm x 15cm in size when folded away
- Reflective logos

Dimensions:

Height: 48cm

Width: 30cm

Depth: 22cm



CODE

OL858

LUGGAGE

TOP BOX

Essential rear hard case

FEATURE HEADER

- Supplied with universal fitting kit and base
- Anti-tamper mechanism for removing from base plate
- Made from High Impact Plastic
- Built-in reflector

OL209 (52L):
Height: 30.5cm
Width: 58.5cm
Depth: 43cm

OL208 (30L):
Height: 29cm
Width: 38.5cm
Depth: 38.5cm



CODE	DESCRIPTION
OL209	Top Box - 52L
OL201P	Spare base for 52L
OL208	Top Box - 30L
OL200P	Spare base for 30L



AQUA D

Waterproof packaging cubes

FEATURES

- Tough lightweight Nylon material
- Internally taped seams
- Set included 5L, 7L and 12L capacity bags
- 100% waterproof and dustproof material

5L: Height: 29cm Diameter: 17cm
7L: Height: 35cm Diameter: 19cm
12L: Height: 40cm Diameter: 21cm



CODE	DESCRIPTION
OL901	Aqua D

X RIDER

Multi-purpose 15L backpack



CODE	DESCRIPTION
OL812	X-Rider - Silver
OL813	X-Rider - Fluo
OL817	X-Rider - Blue



BRIGHT COVER

Reflective backpack cover

FEATURES

- Reflective details
- Unique, universal and waterproof
- Packs away neatly into a compact pouch
- Fits 12 - 35L Backpacks
- Dimensions:
640 x 720mm

"This waterproof hi-vis rucksack cover helps you to be seen and keeps your stuff dry...I found it particularly useful when riding home work with my laptop in my rucksack: I felt a lot safer, and I knew my computer would stay dry!"

MCN

CODE	DESCRIPTION
------	-------------

RE101Y	Yellow
RE101O	Orange



SHIFT GUARD

Shoe protector

FEATURES

- Universal fit secured with elastic hook & loop
- Durable material
- Protects shoe from gear shift

CODE

OX674



ZIP PULLERS

Replacement zip pullers

FEATURES

- Replacement zip pullers
- Durable metal/polymer construction
- Withstand up-to 18kg of tensile force
- Pack of 4

CODE

OX806



BELT CONNECTOR

Jeans to jacket

FEATURES

- Connects jeans to a motorcycle jacket, to prevent an uncomfortable gap forming between the two when riding
- Top quality YKK zip is compatible with all Oxford motorcycle jackets
- Elasticated section allows for movement on the bike without discomfort
- Unobtrusive design - can simply be left on your belt when not in use
- Made using genuine leather



CODE

CA900





DISPLAY STANDS & POS

ADVANCED ACCESSORIES WALL UNIT

PC5000



ADVANCED FLEXIBLE UNIT

PC8010



SINGLE SIDED WALL UNIT

PC8040



DISPLAY UNIT

PC5015



MINT DISPLAY UNIT

PCMINTA&B



MERCHANDISING STANDS

CLIQR



Counter Top
PCCLIQRA



Base
PCCLIQRB



You could have a run of PCCLIQRB to form a counter or divider

PCCLIQRA & B can be placed side-by-side or back to back



LUGGAGE STAND

PC3016

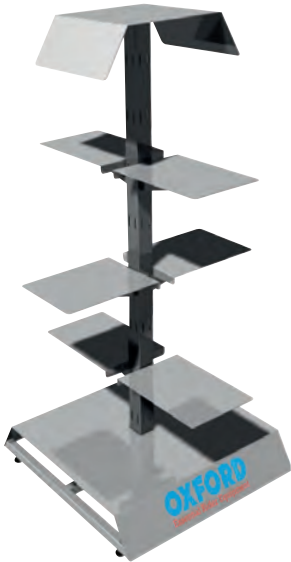

DISC LOCK DISPLAY

PCLOCK



HOTGRIPS DEMO UNIT

PCHOTGRIBEVO



FACE MASK

ODFM



TEAM KIT



HOODIE



POLO



T-SHIRT



MINT T-SHIRT

MERCHANDISING STANDS

WORKSHOP MATS

PCMATA&B



PODIUM DISPLAY UNIT

PC5070



ZERO-G Paddock STAND

These stands can be positioned against a wall or back-to-back



PCZEROC



PCZEROB

PCZEROA

DUMP BIN

POS12



2-SIDED DISPLAY

POS13



- A**
- ALARM-D 19
 - ALPHA XA14 27
 - ANACLOCK 142
 - ANCHORFORCE 23
 - ANCHORS 20-25
 - ANTI-FOG SPRAY 99
 - AQUA 166-171
 - AQUA D 190
 - AQUATEX 38-40
- B**
- BACKPACKS 171-173, 181, 183, 189-190
 - BAR END MUFFS 140
 - BAR ENDS 132
 - BARRIER 16
 - BAR STRAP HARNESS 162
 - BAR STRAP KIT 162
 - BATTERY ACCESSORIES 49-50
 - BATTERY CHARGERS 44-47
 - BEAST 11, 21, 22, 33
 - BELT CONNECTOR 191
 - BIKE DEGREASER 96
 - BIKE WASH 95
 - BLANKET 110
 - BOBBINS 73
 - BOOTSACK 187
 - BOOTSTASH 187
 - BOSS 13
 - BOSS ALARM 12, 27
 - BOTTLE STASH 75
 - BRAKE CLEANER 96
 - BRIGHT COVER 191
 - BRUSHES 90-91
 - BRUTEFORCE 25
 - BUCKET 86
 - BUNG 85
 - BUNGEES 161
- C**
- CABLE LUBE TOOL 83
 - CABLE REPAIR KIT 83
 - CABLE TIES 91
 - CAM STRAPS 160
 - CARABINER STRAPS 163
 - CARB ENDS 133
 - CARGO NETS 161
 - CHAIN CLEANER 96
 - CHAIN LOCKS 10-15
 - CHAINS 32-33
 - CHAIN TOOL 83
 - CLAMP-ON 143
 - CLEAN GRIPS 129
 - CLEANING 86-91
 - CLIQR 144-152
 - CLOCKS 142
 - CO2 105
 - COMBINATION PADLOCK 16
 - COVERS 34-43
 - COVER SIZE GUIDES 43
 - CRUISE 143
- D**
- DEVICE MOUNTS 144-153
 - DIGICLOCK 142
 - DISC LOCKS 26-31
 - DISCUS CHAIN 10 14
 - DOCKING STATION 22
 - DOOR MATS 79
 - DORMEX 42
 - DRIP PADS 89
 - DRYPHONE 153
 - DRYSTASH 187
- F**
- F-1 184-186
 - FIRST AID KIT 160
 - FRAME FORKS 73
 - FUEL FLASK 75
- G**
- GARAGE SIGN 80
 - GEAR TIDY 74
 - GENERAL PROTECTANT 98
 - GP CHAIN 15
 - GRIPS 122-131
- H**
- HAND GUARDS 134
 - HANDY SACK 189
 - HARDCORE XC13 14
 - HD CHAIN 15
 - HD MAX 14
 - HEATED GRIPS 122-129
 - HEAVY DUTY HANGER 74
 - HELMET CARE KIT 99
 - HELMET CARRIER 188-189
 - HELMET CARRY STRAP 189
 - HELMET CLEANER 99
 - HELMET SANITISER 99
 - HERITAGE LUGGAGE 182-183
 - HEX KEY 84
 - HORIZON 136-139
 - HORNS 86
 - HOTGRIPS 122-129
- I**
- INDICATOR ACCESSORIES 120
 - INDICATORS 112-119
 - INSULEVER 143
- J**
- JACKETSTASH 187
- K**
- KNEE GRIPS 108-110
- L**
- LEG BAGS 170, 180
 - LEVER GUARDS 134-135
 - LEVERLOCK 16
 - LEVER SLEEVES 143
 - LIDSACK 188
 - LIDSTASH 188
 - LID STRAP 189
 - LIGHTING 111-121
 - LOCKS 8-33
 - LOOP LOCK 17
 - LUGGAGE 164-191
- M**
- MAGNETO 85
 - MAGNIMATE 159
 - MAGNUM 19
 - MATS 76-78
 - MICRO XA5 28
 - MINDER CABLE 17
 - MINT 94-100
 - MONSTER 13, 29
 - MUFFS 140-141
- N**
- NEMESIS 11, 29
- O**
- OIL CHANGE ACCESSORIES 85
 - OXIMISER 45-47
- P**
- PADDOCK STANDS 51-74
 - PADOCK MATE 159
 - PAINT PROTECTION 106-110
 - PANNIERS 170, 177, 183, 185
 - PATRIOT 12, 29
 - PHONE HOLDER 175
 - PHONE MOUNTS 144-153
 - PROTEX STRETCH 35, 42
- Q**
- QR MECHANISM 165
 - QUARTZ XA10 + XA6 28
- R**
- RAINEX 37
 - RAMP 163
 - RATCHET HOOK STRAPS 162
 - REFLECTORS 84
 - RETRA CABLE 16
 - RIDER GRIPS 160
 - ROLL BAGS 167
 - ROLL BAGS 183, 187
 - ROTAFORCE 23
 - R-SERIES 176-181
- S**
- SCOOT COVERS 41
 - SCREAMER 7 28
 - SCREEN SCREWS 74
 - SECURITY 8-33
 - SEQUENTIAL INDICATORS 112-115
 - S-HOOK STRAPS 163
 - SILICONE DETAILER 98
 - SOCKET SET 82
 - SOLARISER 48
 - SOLO 82
 - SPINDLE KEY 82
 - SPINNERS 73
 - S-SERIES 174-179
 - STAND SUPPORTS 159
 - STORMEX 36
 - STRAP-NAV 153
 - STRIKEFORCE 24
 - SUPER MUFFS 141
- T**
- TAIL LIGHT 120
 - TAIL PACKS 168, 175, 177, 178, 185-186
 - TANK BAGS 168-169, 175, 177-180, 185-186
 - TANK PADS 107-109
 - TASKFORCE 25
 - TAX DISC HOLDERS 92
 - TERAFORCE 24
 - TOOL KIT 81
 - TOOLS 82-83
 - TOOLSTASH 81, 189
 - TOP BOXES 190
 - TOWEL 88-89
 - TYRE CARE 104-105
 - TYRE REPAIR 105
- U**
- U-LOCKS 18-19
 - UMBRATEX 40
- V**
- VALVE TOOLS + ACCESSORIES 104
 - VISORSTASH 188
- W**
- WAIST BAGS 181
 - WAX REPROOFER 100
 - WHEEL STRIPES 104
 - WORKSHOP MATS 76-78
- X**
- X RIDER 190
- Z**
- ZERO-G 51-68
 - ZIP PULLERS 191



OXFORDPRODUCTS.COM



PC143 2022
International
Oxford Accessories



5 030009 416767 >

V.1 MOTORCYCLE ACCESSORIES 2022



/OXFORDPRODUCTS